



# D8 DZUS® PANEX Quarter-Turn Fasteners

## Studs · Size 4



Rivit srl via Marconi 20 - 40064 - Ozzano dell'Emilia (BO)  
Per info 051 4171115 - luca.chiarelli@rivit.it

### Material and Finish

Studs: Steel, zinc plated plus chromate or chrome plated  
Bail cover: ABS, black

82

85

D8

D9

D1

D4

D5

D7

NY



### Installation Notes

Bail cover:

A Retainer must be fitted under the stud head to fit flush with surface

Retainer part number

D8-324-100-040 (see page 397)

### H Head Styles - Tool Actuated

Oval Slot

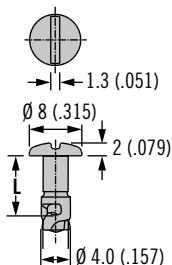

Hex Recess

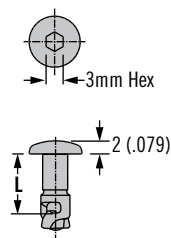

Phillips Recess

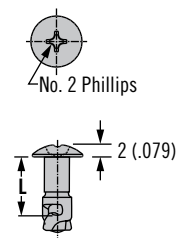

### H Head Styles - Hand Actuated

Wing

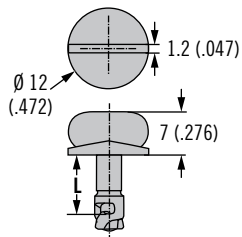

Bail

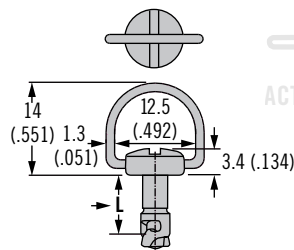

### Optional Bail Cover

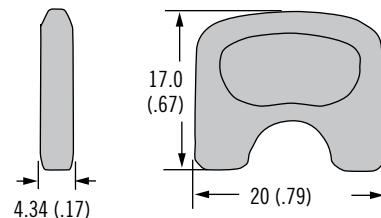
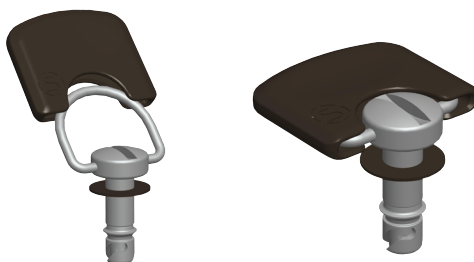

Bail Cover Part Number
D8-4-B-000

### Stud Panel Preparation

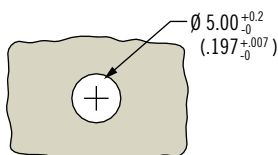

Dimensions in millimeters (inch) unless otherwise stated



[www.southco.com/D8](http://www.southco.com/D8)

DZUS®

southco®  
CONNECT · CREATE · INNOVATE



Rivit srl via Marconi 20 - 40064 - Ozzano dell'Emilia (BO)  
Per info 051 4171115 - luca.chiarelli@rivit.it

# D8 DZUS® PANEX Quarter-Turn Fasteners

Stud selection · Size 4



## Part Number Selection

### H Head style

- 1 Slot recess
- 2 Hex recess
- 3 Wing
- 4 Bail
- 7 Phillips recess

### K Length

Enter number from selection table below

D8 - 314 - H K - F

### F Finish

- 170 Chrome plated
- 190 Zinc plated
- 191 Zinc plated, black

Stud Length Table

A		B		C		D		E		K	L ±.15 ±(.006)
TMT Range For: D8-334-400-121 D8-334-500-121		TMT Range For: D8-334-300-121 D8-334-310-121		TMT Range For: D8-334-200-190		TMT Range For: D8-334-100-300		TMT Range For: D8-334-110-190			
Min.	Max.	Min.	Max.	Min.	Max.	Min.	Max.	Min.	Max.		
1.0 (.04)	1.9 (.07)	1.5 (.06)	2.4 (.09)	~	~	~	~	~	~	08	8 (.315)
2.0 (.08)	2.9 (.11)	2.5 (.10)	3.4 (.13)	~	~	~	~	~	~	09	9 (.354)
3.0 (.12)	3.9 (.15)	3.5 (.14)	4.4 (.17)	~	~	0.7 (.03)	1.6 (.06)	1.7 (.07)	2.6 (.10)	10	10 (.394)
4.0 (.16)	4.9 (.19)	4.5 (.18)	5.4 (.21)	~	~	1.7 (.07)	2.6 (.10)	2.7 (.11)	3.6 (.14)	11	11 (.433)
5.0 (.20)	5.9 (.23)	5.5 (.22)	6.4 (.25)	1.5 (.06)	2.4 (.09)	2.7 (.11)	3.6 (.14)	3.7 (.15)	4.6 (.18)	12	12 (.472)
6.0 (.24)	6.9 (.27)	6.5 (.26)	7.4 (.29)	2.5 (.10)	3.4 (.13)	3.7 (.15)	4.6 (.18)	4.7 (.19)	5.6 (.22)	13	13 (.512)
7.0 (.28)	7.9 (.31)	7.5 (.30)	8.4 (.33)	3.5 (.14)	4.4 (.17)	4.7 (.19)	5.6 (.22)	5.7 (.22)	6.6 (.26)	14	14 (.551)
8.0 (.31)	8.9 (.35)	8.5 (.33)	9.4 (.37)	4.5 (.18)	5.4 (.21)	5.7 (.22)	6.6 (.26)	6.7 (.26)	7.6 (.30)	15	15 (.591)
9.0 (.35)	9.9 (.39)	9.5 (.37)	10.4 (.41)	5.5 (.22)	6.4 (.25)	6.7 (.26)	7.6 (.30)	7.7 (.30)	8.6 (.34)	16	16 (.630)
10.0 (.39)	10.9 (.43)	10.5 (.41)	11.4 (.45)	6.5 (.26)	7.4 (.29)	7.7 (.30)	8.6 (.34)	8.7 (.34)	9.6 (.38)	17	17 (.669)
11.0 (.43)	11.9 (.47)	11.5 (.45)	12.4 (.49)	7.5 (.30)	8.4 (.33)	8.7 (.34)	9.6 (.38)	9.7 (.38)	10.6 (.42)	18	18 (.709)
12.0 (.47)	12.9 (.51)	12.5 (.49)	13.4 (.53)	8.5 (.33)	9.4 (.37)	9.7 (.38)	10.6 (.42)	10.7 (.42)	11.6 (.46)	19	19 (.748)
13.0 (.51)	13.9 (.55)	13.5 (.53)	14.4 (.57)	9.5 (.37)	10.4 (.41)	10.7 (.42)	11.6 (.46)	11.7 (.46)	12.6 (.50)	20	20 (.787)
14.0 (.55)	14.9 (.59)	14.5 (.57)	15.4 (.61)	10.5 (.41)	11.4 (.45)	11.7 (.46)	12.6 (.50)	12.7 (.50)	13.6 (.54)	21	21 (.827)
15.0 (.59)	15.9 (.63)	15.5 (.61)	16.4 (.65)	11.5 (.45)	12.4 (.49)	12.7 (.50)	13.6 (.54)	13.7 (.54)	14.6 (.57)	22	22 (.866)
16.0 (.63)	16.9 (.67)	16.5 (.65)	17.4 (.69)	12.5 (.49)	13.4 (.53)	13.7 (.54)	14.6 (.57)	14.7 (.58)	15.6 (.61)	23	23 (.906)
17.0 (.67)	17.9 (.70)	17.5 (.69)	18.4 (.72)	13.5 (.53)	14.4 (.57)	14.7 (.58)	15.6 (.61)	15.7 (.62)	16.6 (.65)	24	24 (.945)
18.0 (.71)	18.9 (.74)	18.5 (.73)	19.4 (.76)	14.5 (.57)	15.4 (.61)	15.7 (.62)	16.6 (.65)	16.7 (.66)	17.6 (.69)	25	25 (.984)
19.0 (.75)	19.9 (.78)	19.5 (.77)	20.4 (.80)	15.5 (.61)	16.4 (.65)	16.7 (.66)	17.6 (.69)	17.7 (.70)	18.6 (.73)	26	26 (1.02)
20.0 (.79)	20.9 (.82)	20.5 (.81)	21.4 (.84)	16.5 (.65)	17.4 (.69)	17.7 (.70)	18.6 (.73)	18.7 (.74)	19.6 (.77)	27	27 (1.06)
21.0 (.83)	21.9 (.86)	21.5 (.85)	22.4 (.88)	17.5 (.69)	18.4 (.72)	18.7 (.74)	19.6 (.77)	19.7 (.78)	20.6 (.81)	28	28 (1.10)
22.0 (.87)	22.9 (.90)	22.5 (.89)	23.4 (.92)	18.5 (.73)	19.4 (.76)	19.7 (.78)	20.6 (.81)	20.7 (.81)	21.6 (.85)	29	29 (1.14)
23.0 (.91)	23.9 (.94)	23.5 (.93)	24.4 (.96)	19.5 (.77)	20.4 (.80)	20.7 (.81)	21.6 (.85)	21.7 (.85)	22.6 (.89)	30	30 (1.18)

### To select correct fastener:

#### 1. Select receptacle

Choose a receptacle from pages 394-396

#### 2. Select retainer and accessories

from page 397 and note any adjustment values

#### 3. Specify stud length

Calculate the total material thickness (TMT) using the formula given for the receptacle selected. Find the range of TMT using the length selection table (left) using the column (A, B, C, D or E) given for the receptacle selected.

#### 4. Complete the stud part number

by specifying the head style **H**, stud length **K**, and material **M**

Example:

For rivet-on

D8-334-400-121 use column A  
For TMT value calculated as 5.2 (.206), K = 12

For slotted head style in steel, zinc plated material, completed part number: D8-314-112-190

A complete example can be found on page 377.



- 82
- 85
- D8
- D9
- D1
- D4
- D5
- D7
- NY



# D8 DZUS<sup>®</sup> PANEX Quarter-Turn Fasteners

## Receptacles · Size 4



Rivit srl via Marconi 20 - 40064 - Ozzano dell'Emilia (BO)  
Per info 051 4171115 - luca.chiarelli@rivit.it

### Material and Finish

Steel, zinc immersion coating

### Installation Notes

Install with  $\varnothing 3$  (.125) rivets

### Part Number

See table

### Notes

Utilize stud selection column indicated when choosing a stud length from the stud length table on page 393

### Rivet-On

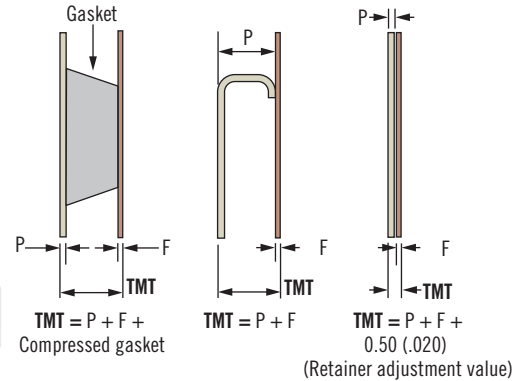
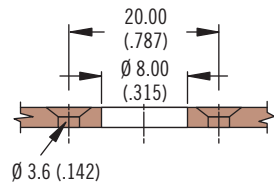
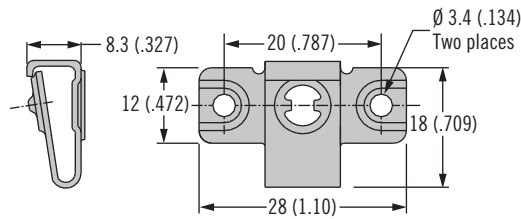

Part Number	Stud Selection Column
D8-334-400-121	A

### Material and Finish

Steel, zinc immersion coating

### Part Number

See table

### Notes

Utilize stud selection column indicated when choosing a stud length from the stud length table on page 393

### Weld-On

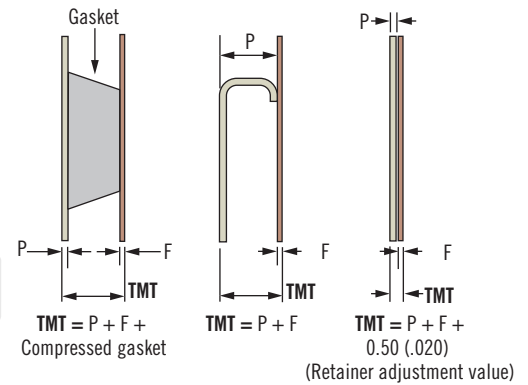
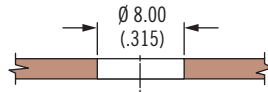
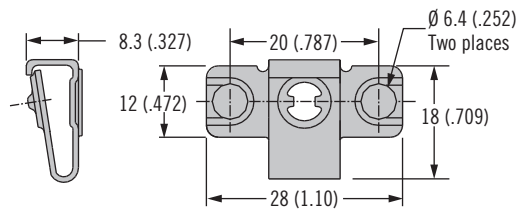

Part Number	Stud Selection Column
D8-334-500-121	A

### Material and Finish

Steel, zinc immersion coating

### Part Number

See table

### Notes

Utilize stud selection column indicated when choosing a stud length from the stud length table on page 393

### Side Mount

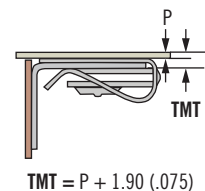
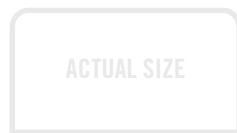
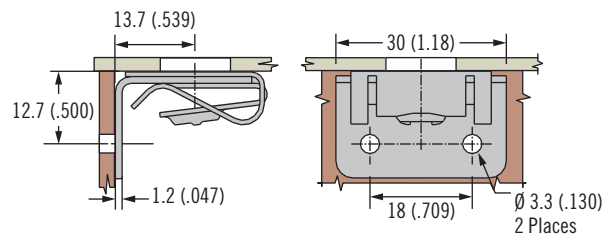

Part Number	Stud Selection Column
D8-334-310-121	B



[www.southco.com/D8](http://www.southco.com/D8)

Dimensions in millimeters (inch) unless otherwise stated

DZUS<sup>®</sup>

southco<sup>®</sup>  
CONNECT · CREATE · INNOVATE



Rivit srl via Marconi 20 - 40064 - Ozzano dell'Emilia (BO)  
Per info 051 4171115 - luca.chiarelli@rivit.it

# D8 DZUS® PANEX Quarter-Turn Fasteners

## Receptacles · Size 4



### Clip-On

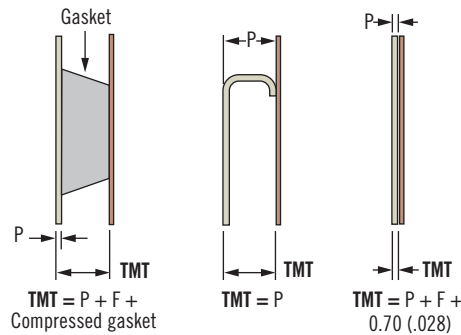
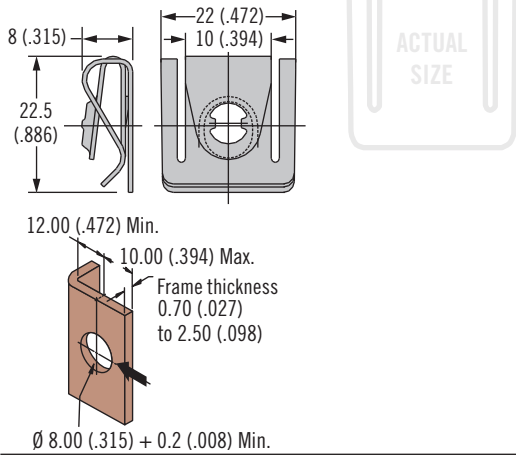

Part Number	Stud Selection Column
D8-334-300-121	B

### Material and Finish

Steel, zinc immersion coating

### Part Number

See table

### Notes

Utilize stud selection column indicated when choosing a stud length from the stud length table on page 393

### Front Mount Clip-In

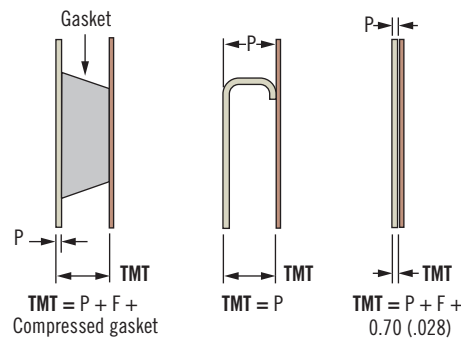
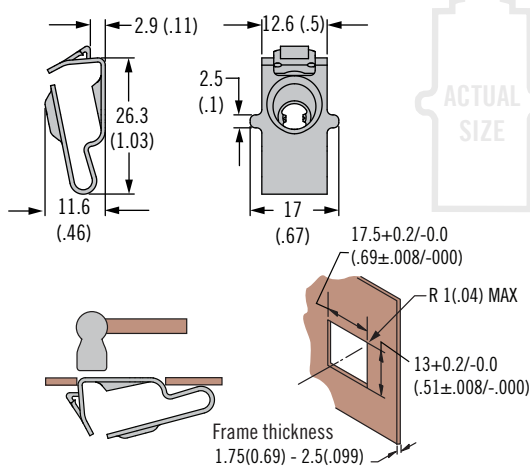

Part Number	Stud Selection Column
D8-334-700-121	B

### Material and Finish

Steel, zinc immersion coating

### Part Number

See table

### Notes

Utilize stud selection column indicated when choosing a stud length from the stud length table on page 393

### Front Mount Snap-In

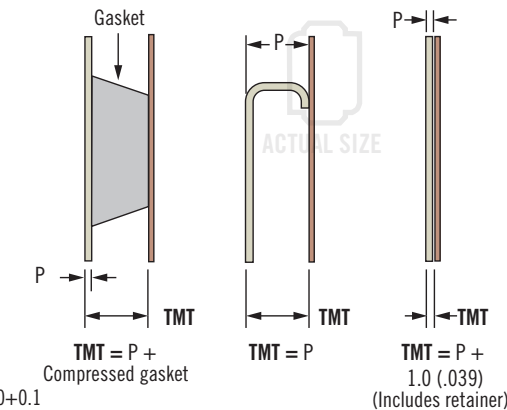
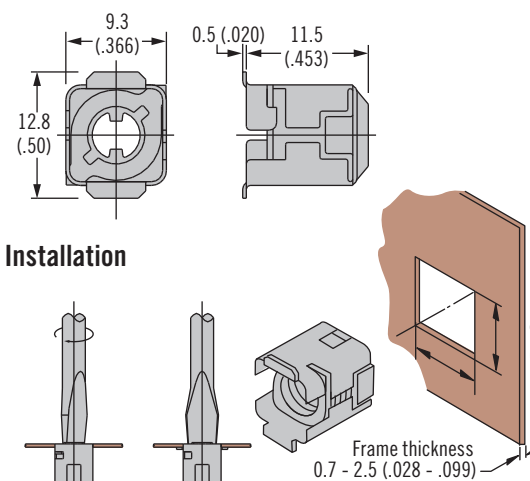

Part Number	Stud Selection Column
D8-334-200-190	C

### Material and Finish

Steel, zinc plated

### Part Number

See table

### Notes

Utilize stud selection column indicated when choosing a stud length from the stud length table on page 393

### Installation

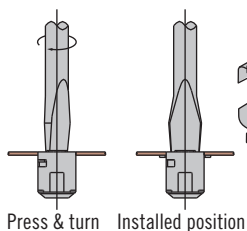

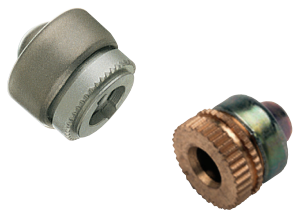

# D8 DZUS<sup>®</sup> PANEX Quarter-Turn Fasteners

## Receptacles · Size 4



Rivit srl via Marconi 20 - 40064 - Ozzano dell'Emilia (BO)  
Per info 051 4171115 - luca.chiarelli@rivit.it

### Material and Finish

Brass and steel, zinc plated

### Installation Notes

Press receptacle flush to frame

### Notes

Receptacle shown installed flush to the frame. To eliminate the gap between the frame and outer panel, install to a depth  $\geq$  the thickness of the selected retainer. This depth should be added to the TMT.

### Press-In - Front Mount

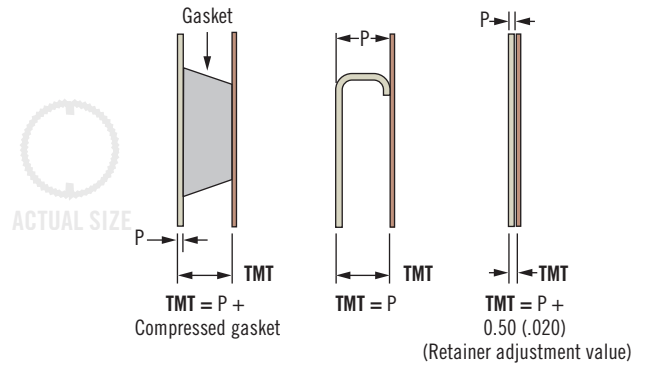
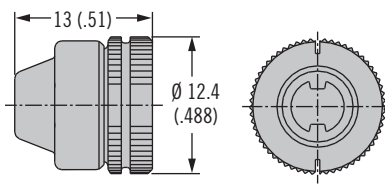

### Solid Install

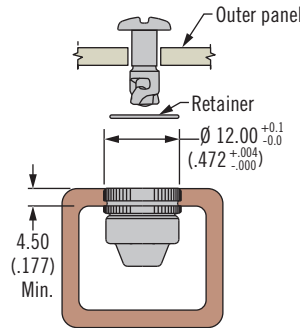

### Blind Install

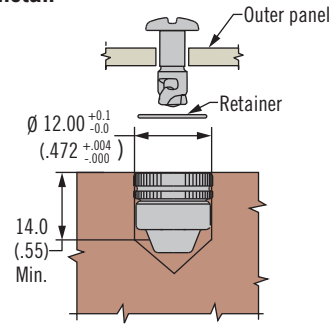

Part Number	Stud Selection Column
D8-334-100-300	D

### Part Number

See table

### Notes

Utilize stud selection column indicated when choosing a stud length from the stud length table on page 393

### Material and Finish

Steel, zinc plated

### Notes

For use in low carbon steels, aluminum and stainless steels in the annealed condition that are RB85 or softer

See page 543 for installation guidelines

### Press-In - Self-Clinching

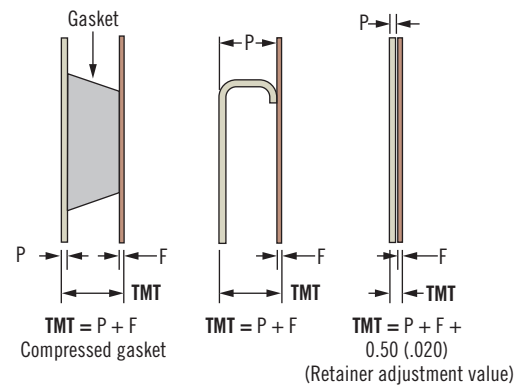
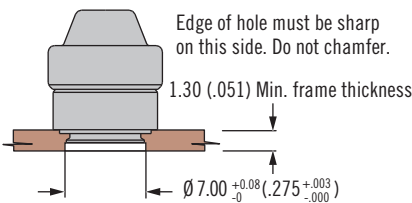
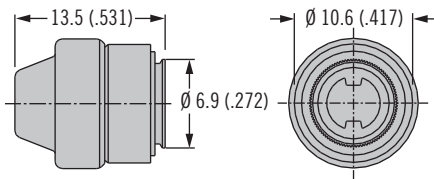

### Part Number

See table

### Notes

Utilize stud selection column indicated when choosing a stud length from the stud length table on page 393

Part Number	Stud Selection Column
D8-334-110-190	E

Dimensions in millimeters (inch) unless otherwise stated



Rivit srl via Marconi 20 - 40064 - Ozzano dell'Emilia (BO)  
Per info 051 4171115 - luca.chiarelli@rivit.it

# D8 DZUS® PANEX Quarter-Turn Fasteners

## Retainers · Accessories · Size 4

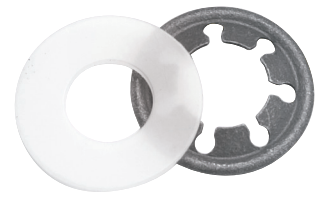

### Retainer Push-On

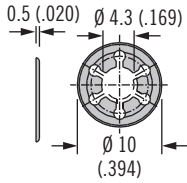

### Retainer Push-On Plastic

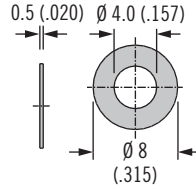

Type	Part Number	Material	Adjustment Value
Push-on plastic	D8-324-100-040	High density polyethylene, black	Included in TMT calculation
Push-on	D8-324-101-200	Stainless steel	

### Material and Finish

See table

### Part Number

See table

82

85

D8

D9

D1

D4

D5

D7

NY



### Retainer Spring (Must be secured with steel retainer)

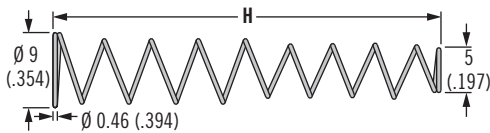

### With Retaining Spring

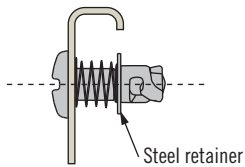

### Without Retaining Spring

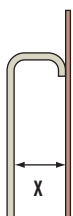
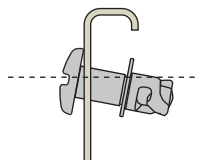

Part Number	H	X Min.	X Max.
D8-324-200-200	48 (1.89)	14 (.551)	44 (1.73)
D8-324-201-200	20 (.787)	5 (.197)	16 (.630)





# D8 DZUS® PANEX Quarter-Turn Fasteners

Studs · Size 6



Rivit srl via Marconi 20 - 40064 - Ozzano dell'Emilia (BO)  
Per info 051 4171115 - luca.chiarelli@rivit.it

## Material and Finish

Studs: Steel, zinc plated and chromate or chrome plated or stainless steel

Key: Steel with zinc plate and chromate

Bail cover: ABS, black

## Accessories

Tamper resistant stud key:

Part number: D8-316-007-969



82

85

D8

D9

D1

D4

D5

D7

NY



## Installation Notes

Bail cover: A Retainer must be fitted under the stud head to fit flush with surface

Retainer part number D8-326-100-040 (see page 403)

## H Head Styles - Tool Actuated

Oval Slot

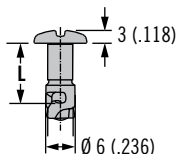
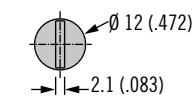

Hex Recess

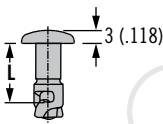
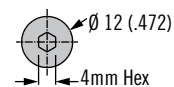

Phillips Recess

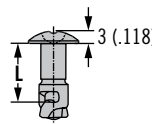
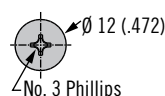

Tamper Resistant

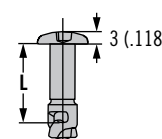
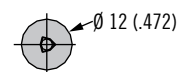

## H Head Styles - Hand Actuated

Wing

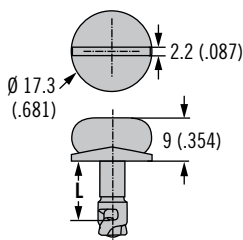

Bail

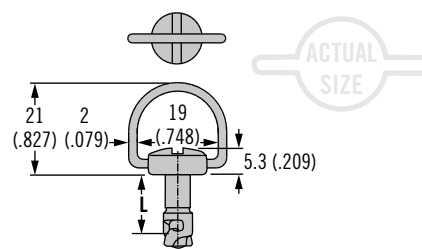

## Optional Bail Cover

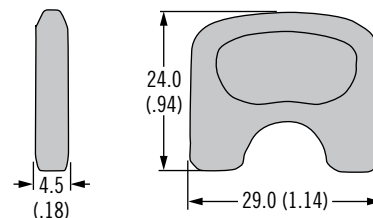
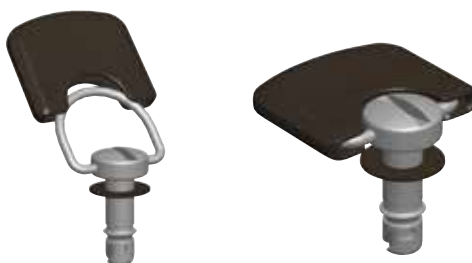

Bail Cover Part Number
D8-6-B-000

## Stud Panel Preparation

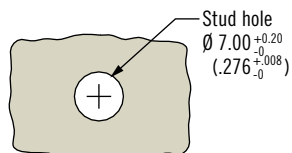

Dimensions in millimeters (inch) unless otherwise stated





Rivit srl via Marconi 20 - 40064 - Ozzano dell'Emilia (BO)  
Per info 051 4171115 - luca.chiarelli@rivit.it

# D8 DZUS® PANEX Quarter-Turn Fasteners

## Stud selection · Size 6



### Part Number Selection

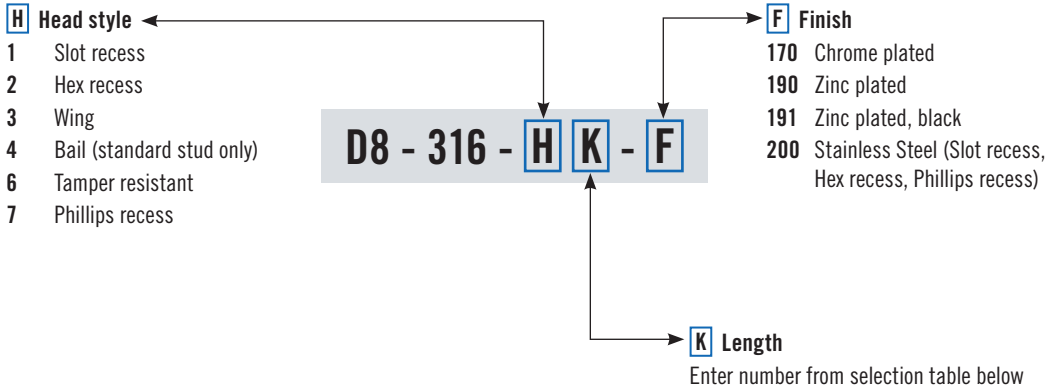

Stud Length Table											
A		B		C		D		E		K	L ±.15 ±(.006)
Min.	Max.	Min.	Max.	Min.	Max.	Min.	Max.	Min.	Max.		
TMT Range For: D8-336-400-121 D8-336-500-121		TMT Range For: D8-336-300-121 D8-336-310-121 D8-336-330-121		TMT Range For: D8-336-200-190		TMT Range For: D8-336-100-300		TMT Range For: D8-336-110-190			
~	~	1.5 (.06)	2.4 (.09)	~	~	~	~	~	~	09	9 (.354)
2.5 (.10)	3.4 (.13)	2.5 (.10)	3.4 (.13)	~	~	~	~	~	~	10	10 (.394)
3.5 (.14)	4.4 (.17)	3.5 (.14)	4.4 (.17)	~	~	~	~	~	~	11	11 (.433)
4.5 (.18)	5.4 (.21)	4.5 (.18)	5.4 (.21)	~	~	0.7 (.03)	1.6 (.06)	1.7 (.07)	2.6 (.10)	12	12 (.472)
5.5 (.22)	6.4 (.25)	5.5 (.22)	6.4 (.25)	~	~	1.7 (.07)	2.6 (.10)	2.7 (.11)	3.6 (.14)	13	13 (.512)
6.5 (.26)	7.4 (.29)	6.5 (.26)	7.4 (.29)	~	~	2.7 (.11)	3.6 (.14)	3.7 (.15)	4.6 (.18)	14	14 (.551)
7.5 (.30)	8.4 (.33)	7.5 (.30)	8.4 (.33)	~	~	3.7 (.15)	4.6 (.18)	4.7 (.19)	5.6 (.22)	15	15 (.591)
8.5 (.33)	9.4 (.37)	8.5 (.33)	9.4 (.37)	0.8 (.03)	1.7 (.07)	4.7 (.19)	5.6 (.22)	5.7 (.22)	6.6 (.26)	16	16 (.630)
9.5 (.37)	10.4 (.41)	9.5 (.37)	10.4 (.41)	1.8 (.07)	2.7 (.11)	5.7 (.22)	6.6 (.26)	6.7 (.26)	7.6 (.30)	17	17 (.669)
10.5 (.41)	11.4 (.45)	10.5 (.41)	11.4 (.45)	2.8 (.11)	3.7 (.15)	6.7 (.26)	7.6 (.30)	7.7 (.30)	8.6 (.34)	18	18 (.709)
11.5 (.45)	12.4 (.49)	11.5 (.45)	12.4 (.49)	3.8 (.15)	4.7 (.19)	7.7 (.30)	8.6 (.34)	8.7 (.34)	9.6 (.38)	19	19 (.748)
12.5 (.49)	13.4 (.53)	12.5 (.49)	13.4 (.53)	4.8 (.19)	5.7 (.22)	8.7 (.34)	9.6 (.38)	9.7 (.38)	10.6 (.42)	20	20 (.787)
13.5 (.53)	14.4 (.57)	13.5 (.53)	14.4 (.57)	5.8 (.23)	6.7 (.26)	9.7 (.38)	10.6 (.42)	10.7 (.42)	11.6 (.46)	21	21 (.827)
14.5 (.57)	15.4 (.61)	14.5 (.57)	15.4 (.61)	6.8 (.27)	7.7 (.30)	10.7 (.42)	11.6 (.46)	11.7 (.46)	12.6 (.50)	22	22 (.866)
15.5 (.61)	16.4 (.65)	15.5 (.61)	16.4 (.65)	7.8 (.31)	8.7 (.34)	11.7 (.46)	12.6 (.50)	12.7 (.50)	13.6 (.54)	23	23 (.906)
16.5 (.65)	17.4 (.69)	16.5 (.65)	17.4 (.69)	8.8 (.35)	9.7 (.38)	12.7 (.50)	13.6 (.54)	13.7 (.54)	14.6 (.57)	24	24 (.945)
17.5 (.69)	18.4 (.72)	17.5 (.69)	18.4 (.72)	9.8 (.39)	10.7 (.42)	13.7 (.54)	14.6 (.57)	14.7 (.58)	15.6 (.61)	25	25 (.984)
18.5 (.73)	19.4 (.76)	18.5 (.73)	19.4 (.76)	10.8 (.43)	11.7 (.46)	14.7 (.58)	15.6 (.61)	15.7 (.62)	16.6 (.65)	26	26 (1.02)
19.5 (.77)	20.4 (.80)	19.5 (.77)	20.4 (.80)	11.8 (.46)	12.7 (.50)	15.7 (.62)	16.6 (.65)	16.7 (.66)	17.6 (.69)	27	27 (1.06)
20.5 (.81)	21.4 (.84)	20.5 (.81)	21.4 (.84)	12.8 (.50)	13.7 (.54)	16.7 (.66)	17.6 (.69)	17.7 (.70)	18.6 (.73)	28	28 (1.10)
21.5 (.85)	22.4 (.88)	21.5 (.85)	22.4 (.88)	13.8 (.54)	14.7 (.58)	17.7 (.70)	18.6 (.73)	18.7 (.74)	19.6 (.77)	29	29 (1.14)
22.5 (.89)	23.4 (.92)	22.5 (.89)	23.4 (.92)	14.8 (.58)	15.7 (.62)	18.7 (.74)	19.6 (.77)	19.7 (.78)	20.6 (.81)	30	30 (1.18)

### To select correct fastener:

#### 1. Select receptacle

Choose a receptacle from pages 400-402

#### 2. Select retainer and accessories

from page 403 and note any adjustment values

#### 3. Specify stud length

Calculate the total material thickness (TMT) using the formula given for the receptacle selected. Find the range of TMT using the stud length selection table (left) using the column (A, B, C, D or E) given for the receptacle selected.

#### 4. Complete the stud part number

by specifying the head style **H**, stud length **K**, and material **M**

Example:

For rivet-on

D8-336-400-121 use column A  
For TMT value calculated as 5.2 (.206), K = 12

For slotted head style in steel material, completed part number: D8-316-112-190

A complete example can be found on page 377.



- 82
- 85
- D8**
- D9
- D1
- D4
- D5
- D7
- NY



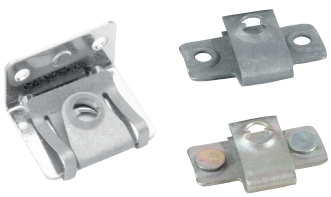

## D8 DZUS<sup>®</sup> PANEX Quarter-Turn Fasteners

Receptacles · Size 6



Rivit srl via Marconi 20 - 40064 - Ozzano dell'Emilia (BO)  
Per info 051 4171115 - luca.chiarelli@rivit.it

### Material and Finish

Steel, zinc immersion coating or stainless steel

### Installation Notes

Install with  $\varnothing 3$  (.125) rivets

### Part Number

See table

### Notes

Utilize stud selection column indicated when choosing a stud length from the stud length table on page 399

### Rivet-On

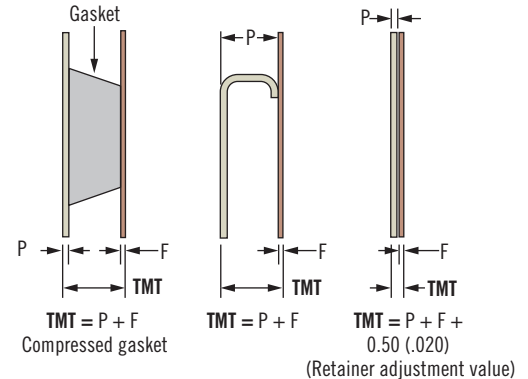
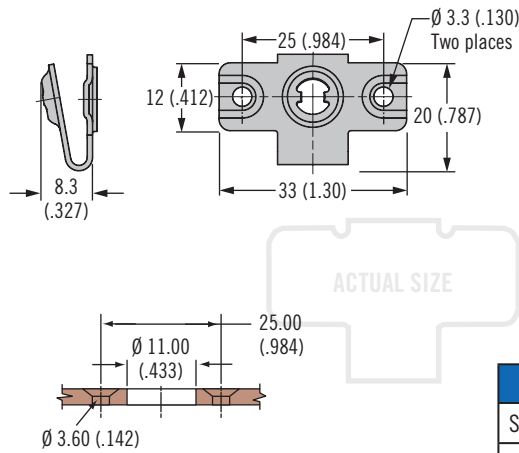

Part Number	Stud Selection Column
Steel	D8-336-400-121
Stainless steel	D8-336-400-200

### Material and Finish

Steel, zinc immersion coating

### Part Number

See table

### Notes

Utilize stud selection column indicated when choosing a stud length from the stud length table on page 399

### Weld-On

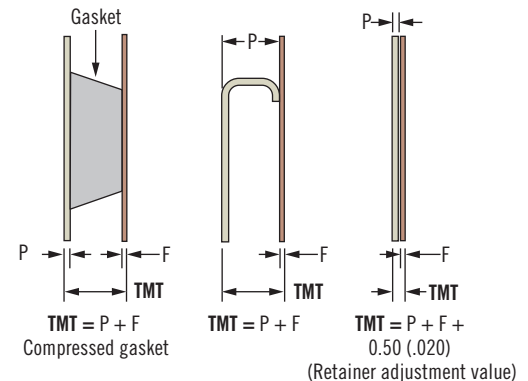
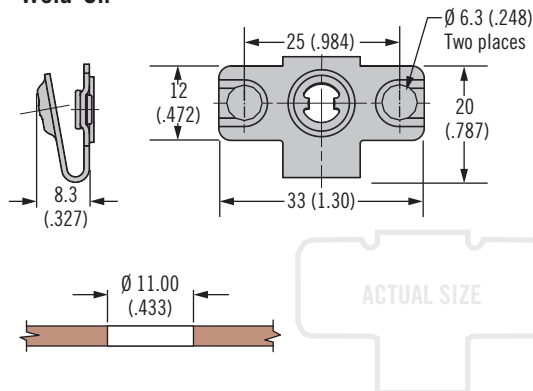

Part Number	Stud Selection Column
D8-336-500-121	A

### Material and Finish

Steel, zinc immersion coating

### Part Number

See table

### Notes

Utilize stud selection column indicated when choosing a stud length from the stud length table on page 399

### Side Mount

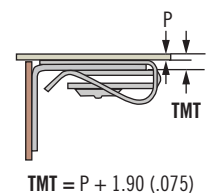
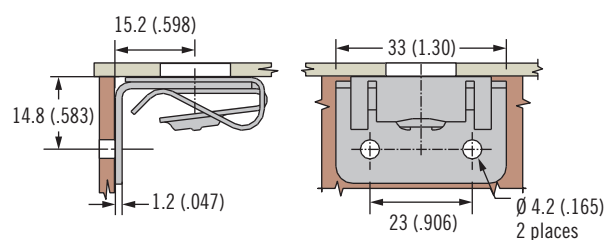

Part Number	Stud Selection Column
D8-336-310-121	B



Rivit srl via Marconi 20 - 40064 - Ozzano dell'Emilia (BO)  
Per info 051 4171115 - luca.chiarelli@rivit.it

# D8 DZUS® PANEX Quarter-Turn Fasteners

## Receptacles · Size 6



### Clip-On

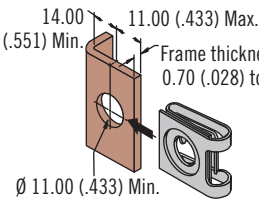
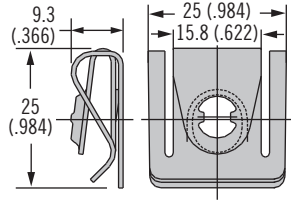

### Clip-On - Mini

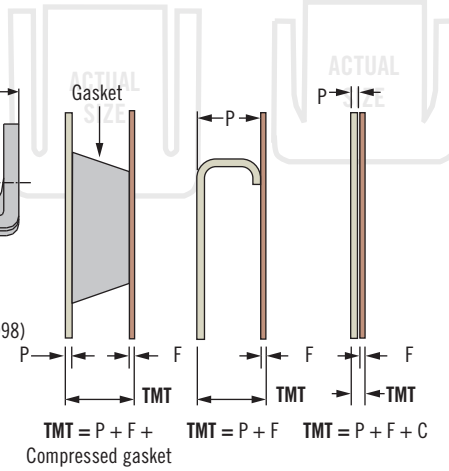
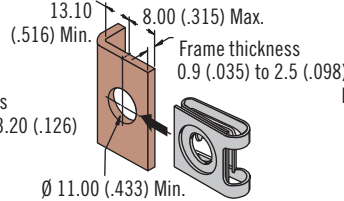
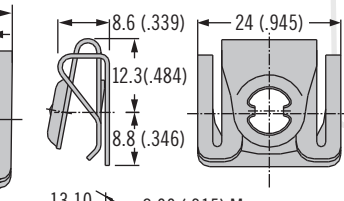

Style	Material	Part Number	C	Stud Selection Column
Clip-On	Steel	D8-336-330-121	0.8(0.031)	B
Clip-On-Mini	Steel	D8-336-330-121	0.7(0.028)	
Clip-On-Mini	Stainless steel	D8-336-330-200		

### Material and Finish

Steel, zinc immersion coating

### Part Number

See table

### Notes

Utilize stud selection column indicated when choosing a stud length from the stud length table on page 399

### Front Mount Clip-In

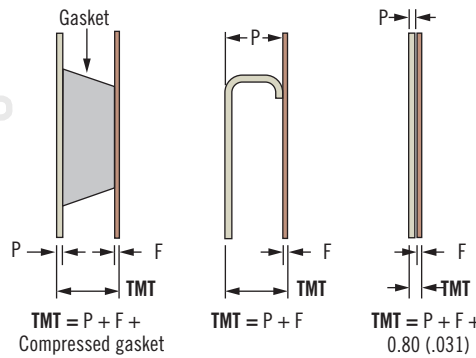
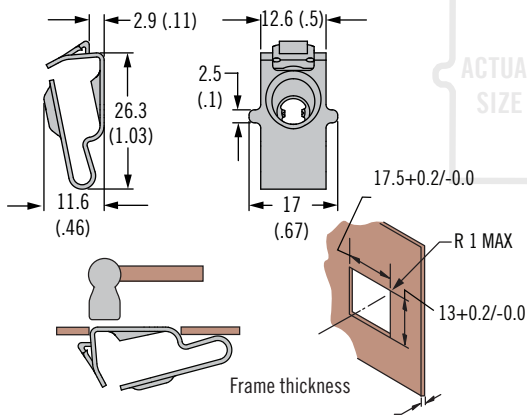

Part Number	Stud Selection Column
D8-336-700-121	B

### Material and Finish

Steel, zinc immersion coating

### Part Number

See table

### Notes

Utilize stud selection column indicated when choosing a stud length from the stud length table on page 399

### Front Mount Snap-In

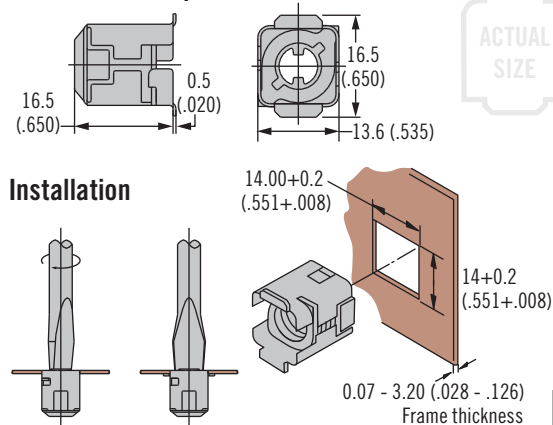

### Installation

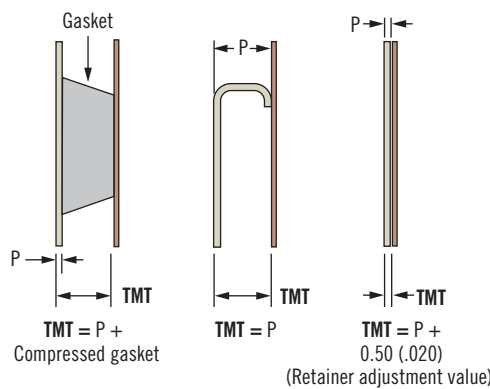
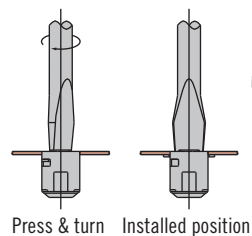

Part Number	Stud Selection Column
D8-336-200-190	C

### Material and Finish

Steel, zinc plated

### Part Number

See table

### Notes

Utilize stud selection column indicated when choosing a stud length from the stud length table on page 399





# D8 DZUS<sup>®</sup> PANEX Quarter-Turn Fasteners

## Receptacles · Size 6



Rivit srl via Marconi 20 - 40064 - Ozzano dell'Emilia (BO)  
Per info 051 4171115 - luca.chiarelli@rivit.it

### Material and Finish

Brass and steel, zinc plated

### Installation Notes

Press receptacle flush to frame

### Notes

Receptacle shown installed flush to the frame. To eliminate the gap between the frame and outer panel, install to a depth  $\geq$  the thickness of the selected retainer. This depth should be added to the TMT.

### Part Number

See table

### Notes

Utilize stud selection column indicated when choosing a stud length from the stud length table on page 399

### Press-In - Front Mount

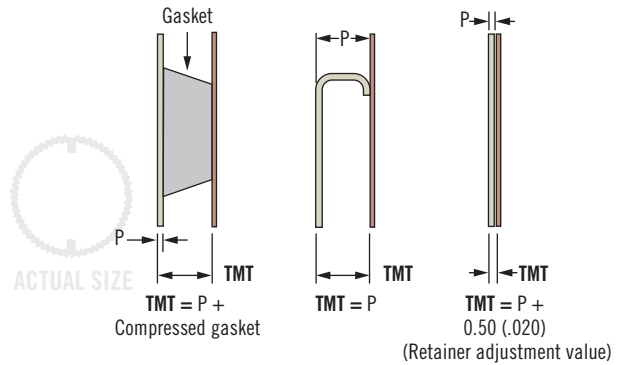
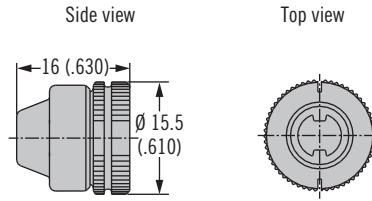

### Solid Install

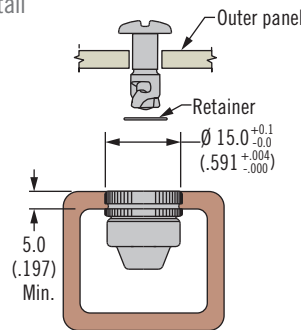

### Blind Install

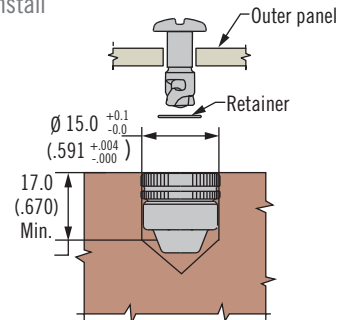

Part Number	Stud Selection Column
D8-336-100-300	D

### Material and Finish

Steel, zinc plated

### Installation Notes

See page 543 for installation guidelines

### Press-In - Self-Clinching

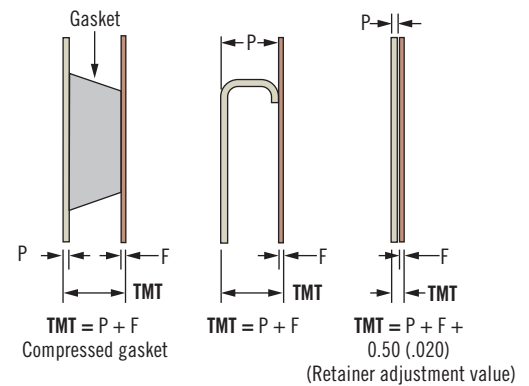
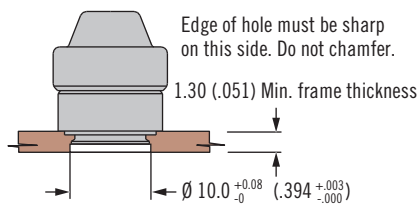
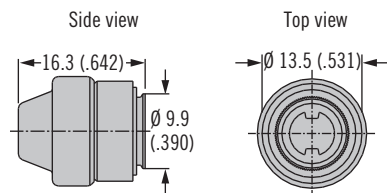

### Part Number

See table

### Notes

Utilize stud selection column indicated when choosing a stud length from the stud length table on page 399

Part Number	Stud Selection Column
D8-336-110-190	E



[www.southco.com/D8](http://www.southco.com/D8)

Dimensions in millimeters (inch) unless otherwise stated





Rivit srl via Marconi 20 - 40064 - Ozzano dell'Emilia (BO)  
Per info 051 4171115 - luca.chiarelli@rivit.it

# D8 DZUS® PANEX Quarter-Turn Fasteners

## Retainers and Accessories · Size 6



### Retainer Push-On, Stainless Steel

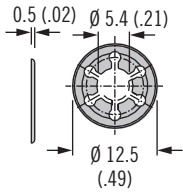

### Retainer Push-On, Plastic

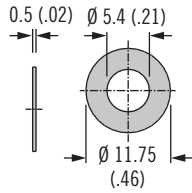

### Cupped Washer

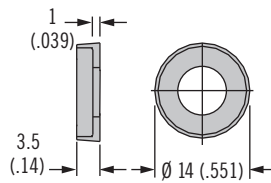

### Ejector Spring

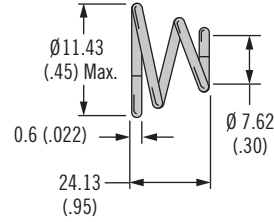

### Ejector Spring and Cup Assembly

(Must be secured with stainless steel retainer)

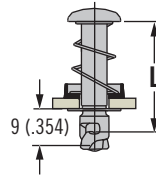

Type	Part Number	Material	Adjustment Value
Push-on plastic	D8-326-100-040	High density polyethylene, black	Included in TMT calculation
Push-on	D8-326-101-200	Stainless steel	
Cupped washer	D8-376-001-049	Thermoplastic, black	Add 1.00 (.039)
Ejector spring	D4-EHF5-3-950QA	Stainless steel	Add 1.00 (.039)

### Retainer Spring (Must be secured with steel retainer)

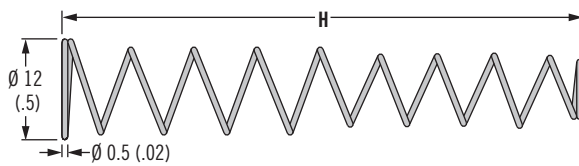

### With Retaining Spring

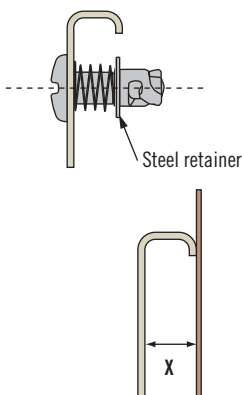

### Without Retaining Spring

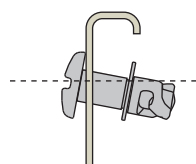

Part Number	H	X Min.	X Max.
D8-326-200-200	48 (1.89)	19 (.75)	44 (1.73)
D8-326-201-200	25 (.98)	5 (.197)	21 (.83)

### Material and Finish

See table

### Accessories

When using the ejecting version add 2 (.079) to your TMT

### Notes

Cupped washer only available for tool recess head styles (slot, Phillips, hex, tamper resistant)

Assembly consists of spring, cup and stud ordered separately, shipped bulk

### Part Number

See table





# D8 *DZUS*<sup>®</sup> PANEX Quarter-Turn Fasteners

Studs · Size 9



Rivit srl via Marconi 20 - 40064 - Ozzano dell'Emilia (BO)  
Per info 051 4171115 - luca.chiarelli@rivit.it

## Material and Finish

Studs: Steel, zinc plated and chromate or chrome plated

82

85

**D8**

D9

D1

D4

D5

D7

NY

## H Head Styles - Tool Actuated

### Oval Slot

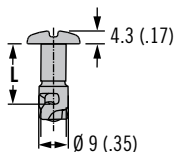
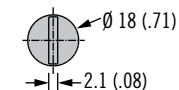

### Hex Recess

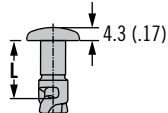
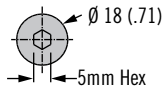

### Phillips Recess

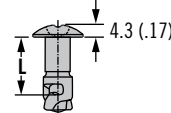
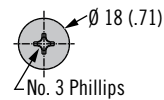

## H Head Styles - Hand Actuated

### Wing

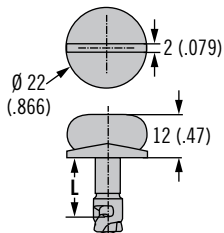

### Bail

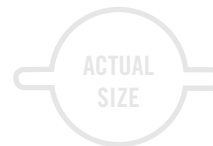
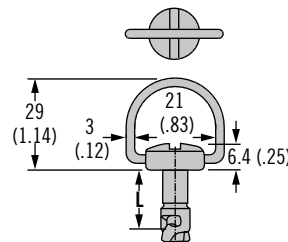

## Stud Panel Preparation

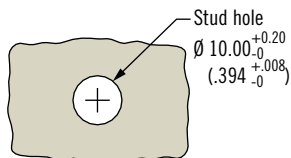

Dimensions in millimeters (inch) unless otherwise stated



[www.southco.com/D8](http://www.southco.com/D8)

**DZUS**<sup>®</sup>

**southco**<sup>®</sup>  
CONNECT · CREATE · INNOVATE

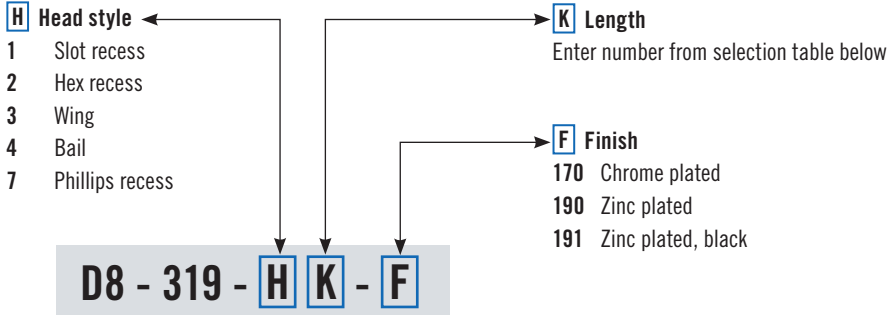

**Part Number Selection**

82

85

**D8**

D9

D1

D4

D5

D7

NY



**To select correct fastener:**

**1. Select receptacle**

Choose a receptacle from pages 406-408

**2. Select retainer and accessories**

from page 409 and note any adjustment values

**3. Specify stud length**

Calculate the total material thickness (TMT) using the formula given for the receptacle selected. Find the range of TMT using the stud length selection table (left) using the column (A, or B) given for the receptacle selected.

**4. Complete the stud part number**

by specifying the head style **H**, stud length **K**, and material **M**

Example:

For rivet-on

D8-339-400-121 use column A  
For TMT value calculated as 5.2 (.206), K = 13

For slotted head style in steel, zinc plated material, completed part number: D8-319-113-190

A complete example can be found on page 377.

**Notes**

Stainless steel material may require a higher minimum order quantity. Contact Southco for details.

Stud Length Table					
A		B		K	L ±.15 (.006)
TMT Range For: D8-339-400-121 D8-339-500-121 D8-339-300-121 D8-339-301-121 D8-339-305-121		TMT Range For: D8-339-200-190			
Min.	Max.	Min.	Max.		
3.0 (.12)	3.9 (.15)	~	~	11	11 (.433)
4.0 (.16)	4.9 (.19)	~	~	12	12 (.472)
5.0 (.20)	5.9 (.23)	~	~	13	13 (.512)
6.0 (.24)	6.9 (.27)	~	~	14	14 (.551)
7.0 (.28)	7.9 (.31)	~	~	15	15 (.591)
8.0 (.31)	8.9 (.35)	~	~	16	16 (.630)
9.0 (.35)	9.9 (.39)	~	~	17	17 (.669)
10.0 (.39)	10.9 (.43)	~	~	18	18 (.709)
11.0 (.43)	11.9 (.47)	~	~	19	19 (.748)
12.0 (.47)	12.9 (.51)	~	~	20	20 (.787)
13.0 (.51)	13.9 (.55)	~	~	21	21 (.827)
14.0 (.55)	14.9 (.59)	2.5 (.10)	3.4 (.13)	22	22 (.866)
15.0 (.59)	15.9 (.63)	3.5 (.14)	4.4 (.17)	23	23 (.906)
16.0 (.63)	16.9 (.67)	4.5 (.18)	5.4 (.21)	24	24 (.945)
17.0 (.67)	17.9 (.70)	5.5 (.22)	6.4 (.25)	25	25 (.984)
18.0 (.71)	18.9 (.74)	6.5 (.26)	7.4 (.29)	26	26 (1.02)
19.0 (.75)	19.9 (.78)	7.5 (.30)	8.4 (.33)	27	27 (1.06)
20.0 (.79)	20.9 (.82)	8.5 (.33)	9.4 (.37)	28	28 (1.10)
21.0 (.83)	21.9 (.86)	9.5 (.37)	10.4 (.41)	29	29 (1.14)
22.0 (.87)	22.9 (.90)	10.5 (.41)	11.4 (.45)	30	30 (1.18)





# D8 DZUS® PANEX Quarter-Turn Fasteners

Receptacles · Size 9



Rivit srl via Marconi 20 - 40064 - Ozzano dell'Emilia (BO)  
Per info 051 4171115 - luca.chiarelli@rivit.it

### Material and Finish

Steel, zinc immersion coating

### Installation Notes

Install with Ø 3 (.125) rivets

82

85

D8

D9

D1

D4

D5

D7

NY

### Part Number

See table

### Notes

Utilize stud selection column indicated when choosing a stud length from the stud length table on page 405

### Rivet-On

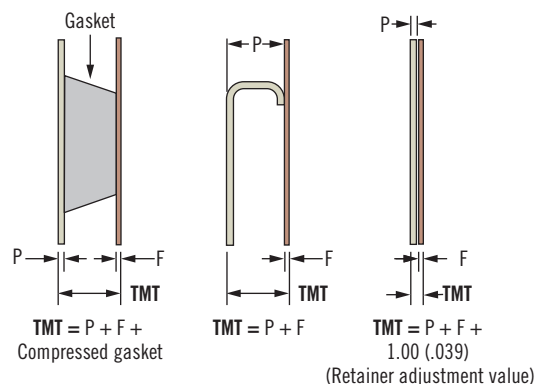
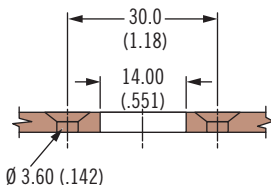
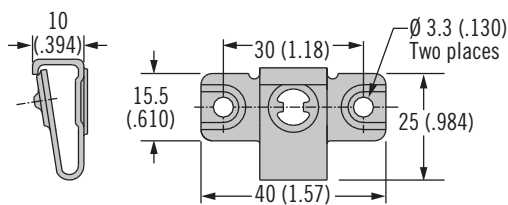

Part Number	Stud Selection Column
D8-339-400-121	A

### Material and Finish

Steel, zinc immersion coating

### Weld-On

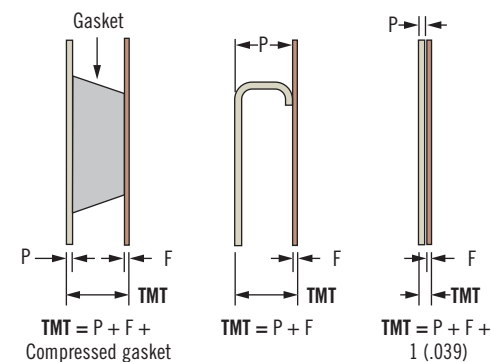
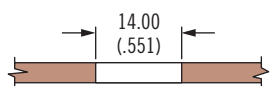
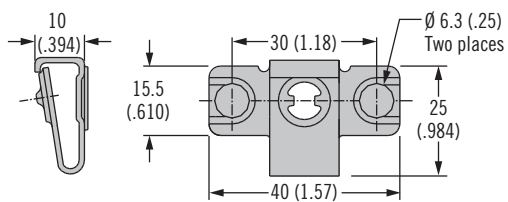

Part Number	Stud Selection Column
D8-339-500-121	A

### Part Number

See table

### Notes

Utilize stud selection column indicated when choosing a stud length from the stud length table on page 405

Dimensions in millimeters (inch) unless otherwise stated





Rivit srl via Marconi 20 - 40064 - Ozzano dell'Emilia (BO)  
Per info 051 4171115 - luca.chiarelli@rivit.it

# D8 DZUS® PANEX Quarter-Turn Fasteners

## Receptacles · Size 9

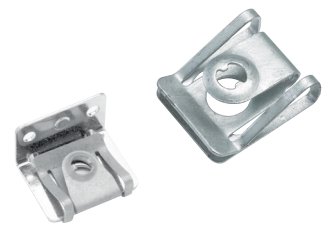

407

### Side Mount

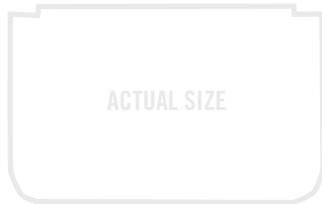
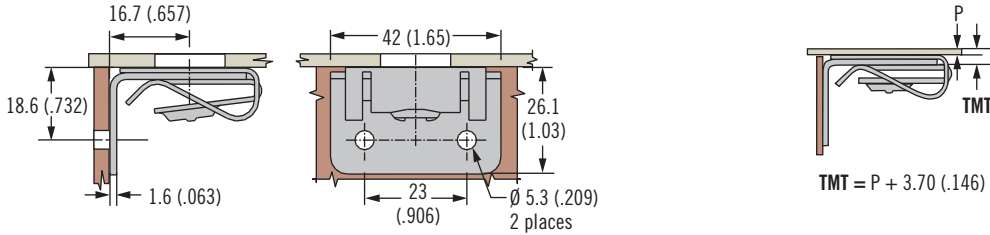

Part Number	Stud Selection Column
D8-339-305-121	A

### Material and Finish

Steel, zinc immersion coating

82

85

D8

D9

D1

D4

D5

D7

NY



### Part Number

See table

### Notes

Utilize stud selection column indicated when choosing a stud length from the stud length table on page 405

### Clip-On

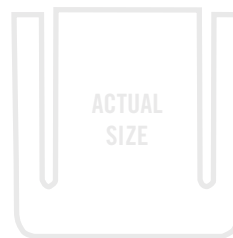
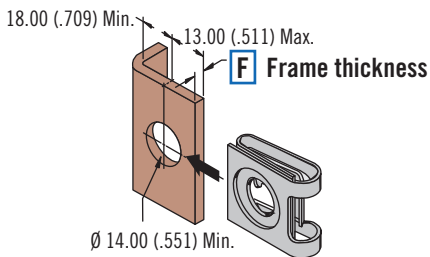
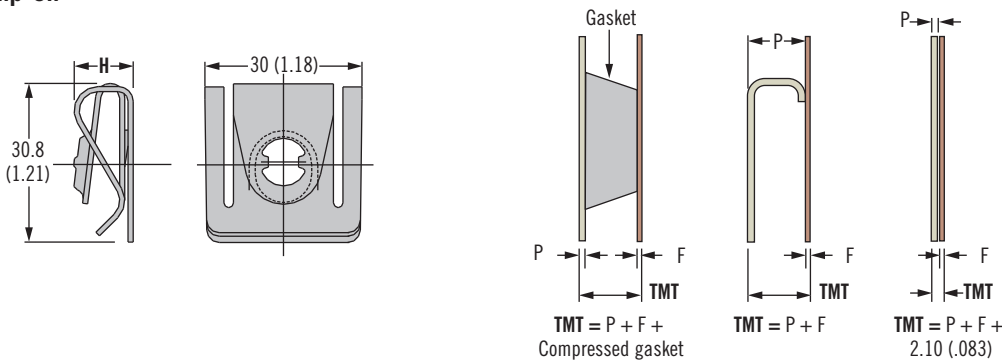

<b>F</b> Frame Thickness Range	Part Number	H	Stud Selection Column
0.7 - 3.2 (.028 - .126)	D8-339-300-121	10.7 (.421)	A
3.2 - 5.5 (.126 - .217)	D8-339-301-121	11.3 (.445)	

### Material and Finish

Steel, zinc immersion coating

### Part Number

See table

### Notes

Utilize stud selection column indicated when choosing a stud length from the stud length table on page 405



# D8 DZUS® PANEX Quarter-Turn Fasteners

## Receptacles · Size 9



Rivit srl via Marconi 20 - 40064 - Ozzano dell'Emilia (BO)  
Per info 051 4171115 - luca.chiarelli@rivit.it

### Material and Finish

Steel, zinc plated

82

85

D8

D9

D1

D4

D5

D7

NY

### Front Mount

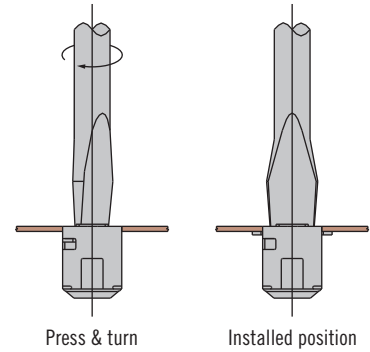
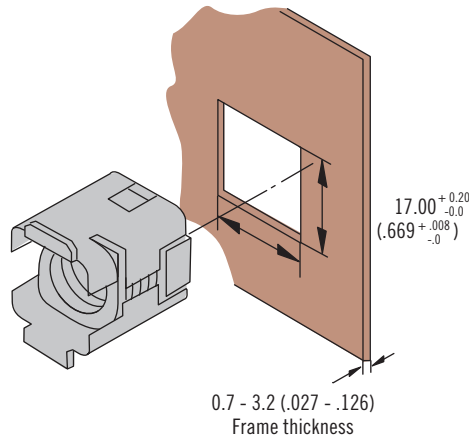
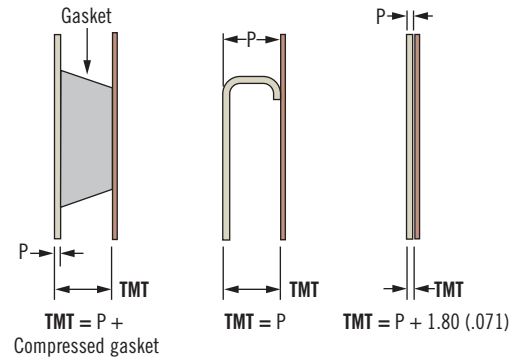
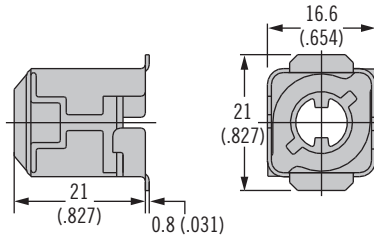

### Part Number

See table

### Notes

Utilize stud selection column indicated when choosing a stud length from the stud length table on page 405

Type	Part Number	Stud Selection Column
Front mount	D8-339-200-190	B



[www.southco.com/D8](http://www.southco.com/D8)

Dimensions in millimeters (inch) unless otherwise stated



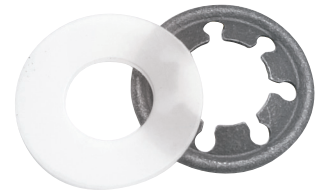

**Retainer Push-On, Plastic**

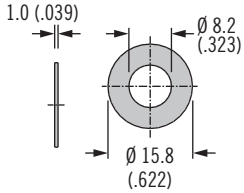

**Retainer Push-On, Steel**

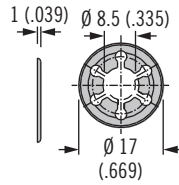

Type	Part Number	Material	Adjustment Value
Push-on Plastic	D8-329-101-040	Nylon 6/6 Black	Included in TMT calculation
Push-on	D8-329-101-200	Stainless steel	

**Retainer Spring** (Must be secured with steel retainer)

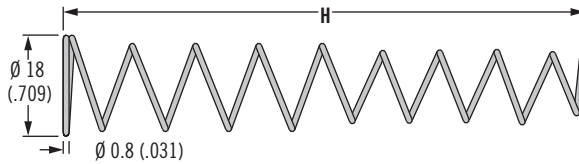

With Retaining Spring

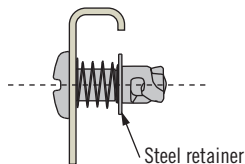

Without Retaining Spring

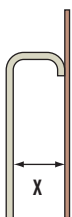
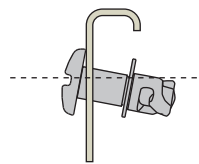

Part Number	H	X Min.	X Max.
D8-329-200-200	48 (1.89)	7 (.276)	43 (1.69)

**Material and Finish**

See table

- 82
- 85
- D8**
- D9
- D1
- D4
- D5
- D7
- NY



# Installation Guidelines

for *SOUTHCO*<sup>®</sup> Self-Clinching products

Self-clinching product installation is offered on these *SOUTHCO*<sup>®</sup> products, making them easy-to-use captive panel fasteners:

- Captive Screws
- Receptacles for Quarter-turn Fasteners
- Receptacles for Fast-lead Thread Screws

When pressed into a properly prepared hole, self-clinching captive fasteners cold-flow (move) the panel material into the retaining groove of the fastener. This material then retains the fastener in the panel.

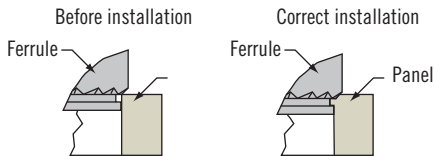

## Successful press-in installations depend on:

### Material:

The hardness of the panel material must not exceed *SOUTHCO*<sup>®</sup> recommendations. If the panel is too hard, the fastener will not install correctly.

### Installation Holes:

Mounting holes may be drilled, punched, or cast.

- Hole edge: the top hole edge must be sharp but with no broken edges.

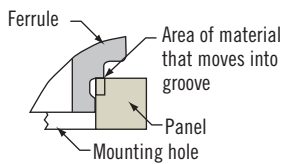

Do not chamfer or debur edge.

- Punched holes: use a punch and die with a small clearance to minimize the rollover and fracture angle.
- Hole diameter: measure the hole diameter at the panel surface on the side on which the fastener will be installed. The diameter must be within *SOUTHCO*<sup>®</sup> specifications for that product.

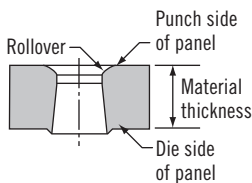

- If the hole is too large, not enough material will flow into the retaining groove and the fastener may not be retained adequately.
- If the hole is too small, the fastener will not fit and installation may become difficult and unsafe.
- Hole distance from the edge of panel: the minimum recommended distance is 1.5 x the diameter of the mounting hole, unless otherwise indicated.

- Spring-loaded Plungers
- Captive Nuts
- Threaded Inserts

- Installing too close to the edge will cause the material to flow in the opposite direction, deforming the edge of the panel. To install closer to the edge, you may need to restrain the panel edge.

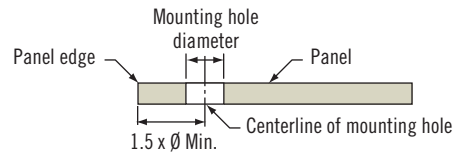

### Panel Thickness:

The thickness of the panel at the mounting hole location must meet or exceed Southco's stated minimum recommendations.

If the material is too thin, panel deformation and/or damage to the fastener may result.

### Installation is fast and easy if you follow these tips:

How to install: Use the recommended force where noted and a proper back-up tool.

- use any parallel-acting press
- use a punch whose diameter is larger than the head of the fastener

Installation Force: Proper installation requires an even distribution of adequate force. It does not depend on the distance the fastener is pressed into the panel.

- Southco does not recommend using a hammer. The impact force does not provide an even distribution of force to allow the panel material to completely flow into the fastener's retaining groove.
- Installation force varies from application to application, depending on the criteria noted above.
- On parts without a collar to provide a hard stop, press-in until the edge of the knurl is just barely visible.

### When to Install:

Installation is recommended after plating or finishing has been applied to the panel.

The hole diameter must meet specifications before finish or plating is applied.

- Do not over-install parts. This interrupts the material and will reduce the retention strength.

