



Rivetti in caricatore

Speed rivets in cartridge



Benefici:

Benefits:

Costo basso

Cost savings

Un risparmio consistente sui costi di installazione può essere realizzato qualora si utilizzino i rivetti in caricatore al posto di saldature a punti, ferramenta sciolta o rivetti tradizionali. *Speed rivets use leads to drastic time saving and consequently to a reduction of the installation costs if compared to traditional hardware, welds and standard blind rivets.*

Installazioni veloci

Quick installation

I rivetti in caricatore possono essere piazzati tanto velocemente quanto un operatore riesce a spostarsi di foro in foro e possono essere installati da sistemi automatici o semiautomatici. *Speed rivets enables rapid installation, depending only on the quickness of the operator, and they can be placed both with automatic or semiautomatic systems.*

Versatile

Versatile

Una vasta gamma di misure di mandrini permette una espansione dei rivetti in caricatore tale da renderli adatti ad ogni variante del foro.

The availability of mandrels in different sizes is so huge to enable our speed rivets to fit any hole size.

Settori di applicazione

Application fields

Automobilistico, elettrodomestico, elettromeccanica, elettronica, arredamenti metallici, illuminotecnica, lavorazione lamiera, giocattoli.

Automotive, household appliances, electromechanics, electronics, metal furnishing, illuminating engineering, sheet metal working, toys.

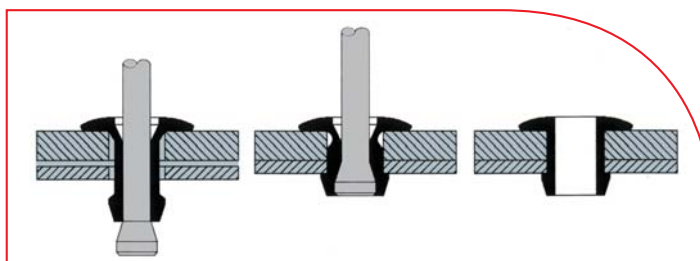

Istruzioni d'uso

Instructions

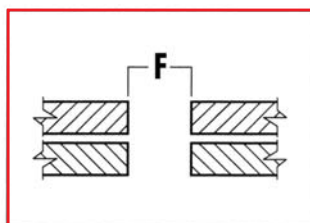

Dimensione foro (es. Ø 3.3).
Hole size (e.g. Ø 3.3).

F: foro
F: bore

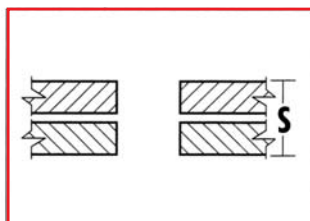

Spessore totale del materiale da serrare (spessore serrabile) (es. 2.5 mm).
Total thickness of material to grip (grip range) (e.g. 2.5 mm).

S: spessore serrabile
S: grip range

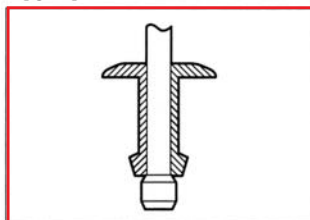

Scegli il rivetto appropriato (es. rivetto in alluminio diametro - Ø 3.2 lunghezza - 5.3 cod. 30129).
Choose the proper fastener (e.g. aluminium speed rivets Ø 3.2 length - 5.3 code 30129).

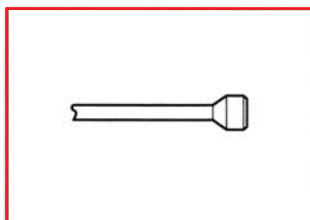

Scegli il mandrino giusto per tipo di rivetto in caricatore (dimensione foro - Ø 3.3 mandrino standard cod. 30194).
Determine the proper mandrel for your speed rivet (hole size - Ø 3.3 standard mandrel code 30194).



Scegli la molla giusta per il tipo di rivetto in caricatore (diametro del rivetto 3.2 molla cod. 30324).
Determine the proper spring for your speed rivet (for rivet Ø 3.2, use spring code 30324).

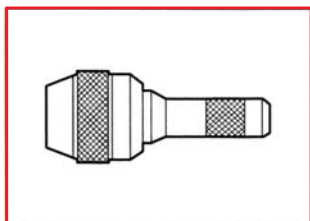

Scegli la testata giusta in base al Ø del rivetto (diametro - 3.2 testata - standard piatta cod: 30195).
Determine the proper head according to rivet Ø (Ø 3.2 standard flat head code 30195).

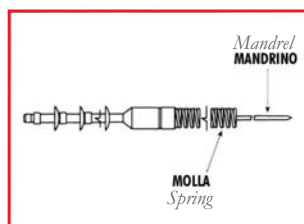

Carica i rivetti sul mandrino, seguiti dalla molla.
Load the fasteners on the mandrel, followed by the spring.



Carica l'attrezzo.
Load the tool.

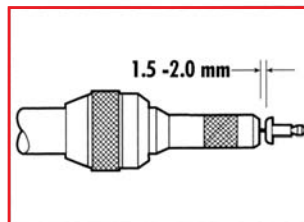

Sistema il primo rivetto in modo che esca di 1.5 - 2.0 mm dalla testata e assicurati della perfetta chiusura del mandrino.
Adjust the first rivet so that it protrudes 1.5 to 2.0 mm from the head and make sure of the perfect closing of mandrel.

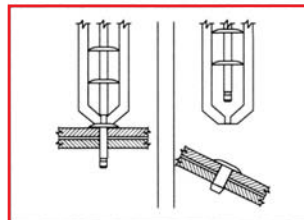

Inserisci il rivetto completamente dentro al foro e tira il grilletto dell'attrezzo.
Place fastener fully into the application hole and start the trigger.

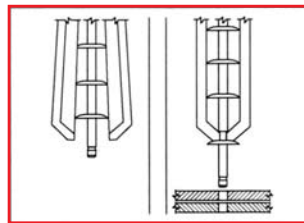

Rilascia il grilletto - il rivetto successivo uscirà automaticamente dalla testata dell'attrezzo.
Release the trigger - the next fastener automatically comes out through the head.

Rivetti in caricatore BR in alluminio

BR aluminium speed rivets



Corpo in alluminio

Aluminium body

Testa tonda

Dome head

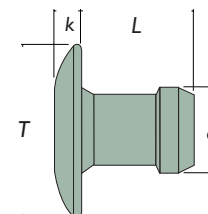
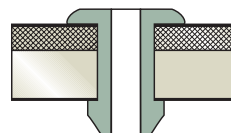

d		L	T	k _{max}				Codice Code	n° pezzi per cartuccia n° of pieces in each cartridge		
mm	mm	mm	mm	mm	mm	N	N	-	-	pz	kg
3.2	3.26 ÷ 3.34	4.3	6.4	1.0	1.1 ÷ 2.4	740	980	30105	58	30000	4.14
		5.3			2.2 ÷ 3.4			30129	48	25000	4.18
		6.3			3.2 ÷ 4.4			30130	42	20000	3.34
		7.3			4.2 ÷ 5.5			30131	37	20000	3.80
		8.3			5.2 ÷ 6.5			30843	33	15000	3.00
		9.3			6.2 ÷ 7.5			30132	30	15000	3.30
4.0	3.97 ÷ 4.04	4.9	8.0	1.15	1.6 ÷ 2.9	900	1500	30133	52	23000	5.65
		5.9			2.7 ÷ 3.9			30134	44	20000	5.10
		6.9			3.7 ÷ 5.0			30135	38	17000	4.80
		7.9			4.7 ÷ 6.0			30136	34	15000	4.64
		8.9			5.7 ÷ 7.0			30137	30	13000	4.25
4.8	4.85 ÷ 4.93	6.1	9.6	1.2	2.0 ÷ 3.9	1300	2500	30138	42	15000	5.80
		7.3			3.7 ÷ 5.2			30139	36	13000	5.11
		8.6			5.0 ÷ 6.5			30140	31	11000	5.00
		9.9			6.2 ÷ 7.7			30141	28	10000	4.79
		11.1			7.5 ÷ 9.0			30142	24	9000	5.08

Rivetti in caricatore

Speed rivets in cartridge



Rivetti in caricatore BR in alluminio

BR aluminium speed rivets



Corpo in alluminio nero RAL 9005

Aluminium body (RAL 9005)

Testa tonda

Dome head

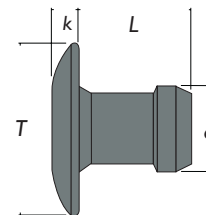
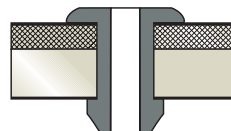

d		L	T	k _{max}				Codice Code	n° pezzi per cartuccia n° of pieces in each cartridge		
mm	mm	mm	mm	mm	mm	N	N	-	-	pz	kg
3.2	3.26 ÷ 3.34	4.3	6.4	1.0	1.1 ÷ 2.4	740	980	32386	58	30000	4.23
		5.3			2.2 ÷ 3.4			32389	48	25000	4.18
		6.3			3.2 ÷ 4.4			32393	42	20000	3.34
		7.3			4.2 ÷ 5.5			32413	37	20000	3.80
		9.3			6.2 ÷ 7.5			32402	33	15000	3.30
4.0	3.97 ÷ 4.04	4.9	8.0	1.15	1.6 ÷ 2.9	900	1500	32414	30	23000	5.65
		5.9			2.7 ÷ 3.9			32415	52	20000	5.10
		6.9			3.7 ÷ 5.0			32416	44	17000	4.80
		7.9			4.7 ÷ 6.0			32417	38	15000	4.64
		8.9			5.7 ÷ 7.0			32418	34	13000	4.25
4.8	4.85 ÷ 4.93	6.1	9.6	1.2	2.0 ÷ 3.9	1300	2500	32419	30	15000	5.80
		7.3			3.7 ÷ 5.2			32420	42	13000	5.11
		8.6			5.0 ÷ 6.5			32421	36	11000	4.97
		9.9			6.2 ÷ 7.7			32422	31	10000	5.08
		11.1			7.5 ÷ 9.0			32423	28	9000	4.74

Rivetti in caricatore

Speed rivets in cartridge



Rivetti in caricatore BR in acciaio

BR zinc coated steel speed rivets

Corpo in acciaio zincato

Zinc coated steel body

Testa tonda

Dome head

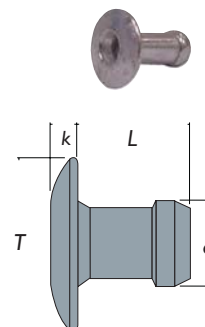
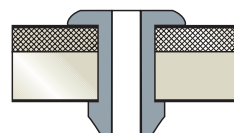

d		L	T	k _{max}				Codice Code	n° pezzi per cartuccia n° of pieces in each cartridge		
mm	mm	mm	mm	mm	mm	N	N	-	-	pz	kg
3.2	3.26 ÷ 3.34	4.3	6.4	1.0	1.1 ÷ 2.4	860	1440	30143	58	30000	10.98
		5.3			2.2 ÷ 3.4			30168	48	25000	9.30
		6.3			3.2 ÷ 4.4			30190	42	20000	8.20
		7.3			4.2 ÷ 5.5			30191	37	20000	9.56
		9.3			6.2 ÷ 7.5			30192	30	15000	7.68
4.0	3.97 ÷ 4.04	4.9	8.0	1.15	1.6 ÷ 2.9	1248	2240	30228	52	23000	13.64
		5.9			2.7 ÷ 3.9			30229	44	20000	13.08
		6.9			3.7 ÷ 5.0			30230	38	17000	11.63
		7.9			4.7 ÷ 6.0			30282	34	15000	11.20
		8.9			5.7 ÷ 7.0			30275	30	13000	10.27
4.8	4.85 ÷ 4.93	6.1	9.6	1.2	2.0 ÷ 3.9	1716	2960	30283	42	15000	14.41
		7.3			3.7 ÷ 5.2			30284	36	13000	12.50
		8.6			5.0 ÷ 6.5			30285	31	11000	12.42
		9.9			6.2 ÷ 7.7			30286	28	10000	12.14
		11.1			7.5 ÷ 9.0			30287	24	9000	11.85

Rivetti in caricatore

Speed rivets in cartridge



Rivetti in caricatore BR in inox Aisi 304

BR stainless steel Aisi 304 speed rivets



Corpo in acciaio inox Aisi 304

Stainless steel Aisi 304 body

Testa tonda

Dome head

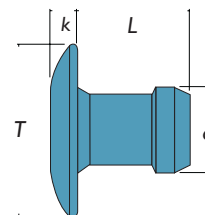
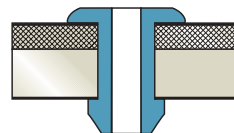

d		L	T	k _{max}				Codice Code	n° pezzi per cartuccia n° of pieces in each cartridge		
mm	mm	mm	mm	mm	mm	N	N	-	-	pz	kg
3.2	3.26 ÷ 3.34	6.4	6.4	1.0	3.17 ÷ 4.45	860	1440	35074	58	20000	8.20
4.0	3.97 ÷ 4.04	6.9			3.68 ÷ 4.96			35075	38	17000	11.1
4.8	4.85 ÷ 4.93	7.3			3.68 ÷ 5.21			35029	36	13000	12.00

Rivetti in caricatore

Speed rivets in cartridge



Rivetti in caricatore BR in alluminio

BR aluminium speed rivets

Corpo in alluminio

Aluminium body

Testa svasata

Countersunk head

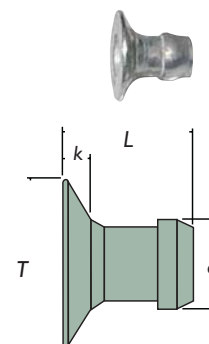
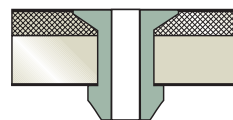

d		L	T	k _{max}				Codice Code	n° pezzi per cartuccia n° of pieces in each cartridge		
mm	mm	mm	mm	mm	mm	N	N	-	-	pz	kg
3.2	3.26 ÷ 3.34	4.8	6.0	0.9	1.5 ÷ 2.8	640	880	30288	64	30000	1.44

Rivetti in caricatore BR in acciaio

BR zinc coated steel speed rivets

Corpo in acciaio zincato

Zinc coated steel body

Testa svasata

Countersunk head

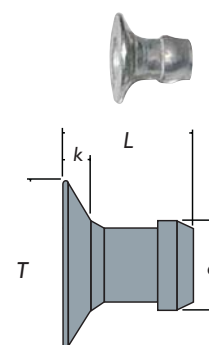
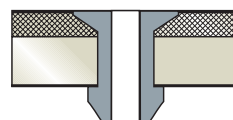

d		L	T	k _{max}				Codice Code	n° pezzi per cartuccia n° of pieces in each cartridge		
mm	mm	mm	mm	mm	mm	N	N	-	-	pz	kg
3.2	3.26 ÷ 3.34	4.8	6.0	0.9	1.5 ÷ 2.8	640	880	30289	64	30000	8.25

Rivetti in caricatore

Speed rivets in cartridge



Rivettatrice oleopneumatica con compensatore

Hydropneumatic riveting tool with compensator

RIV 300

Tipo Type	Codice Code
RIV 300	30108

Per rivetti in caricatore

For cartridge speed rivets

Principio di funzionamento:

I rivetti in caricatore BR hanno il vantaggio di ottenere rivettature veloci a ripetizione, ideale per fissaggi leggeri, prevalentemente per il settore elettromeccanico, elettronico, valigeria, computer.

La RIV 300 viene equipaggiata con appositi ricambi in base al tipo e al Ø del rivetto che si deve utilizzare.

La scelta dei componenti viene effettuata in questo modo:

1. In funzione del Ø del rivetto si sceglie la testata.

2. In funzione del tipo e Ø del rivetto e foro si sceglie il mandrino.

3. In funzione del Ø del rivetto si sceglie la relativa molla.

Operating system:

The rivets in cartridge, BR, are used for quick and repeating riveting; they result to be perfect for light fastening. BR are mostly used for electronic, electromechanic, leather goods and computer applications. RIV 300 is equipped with proper spare parts according to the rivet type and Ø to be placed.

The fittings selection has to be done as follows:

1. Head according to rivet Ø.

2. Mandrel according to rivet type, Ø and hole type.

3. Spring according to rivet Ø.



molla
spring

mandrino
mandrel

testata
head

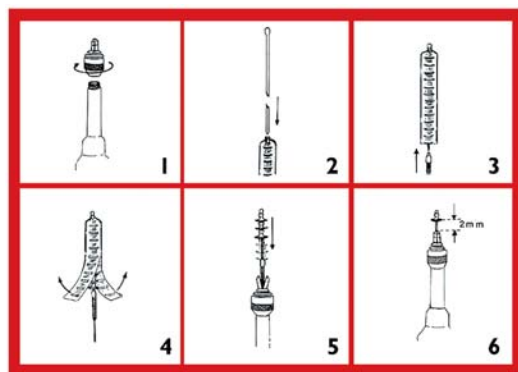

1. Montare la testa
 2. Infilare il mandrino nel caricatore dei rivetti
 3. Inserire la molla nel mandrino
 4. Togliere la carta su cui sono montati i rivetti
 5. Inserire il mandrino nell'attrezzo allargando i beccucci della testata
 6. Bloccare le ganasce dell'attrezzo sul mandrino
1. Screw the head
 2. Insert the mandrel inside the rivet cartridge
 3. Insert the spring in the mandrel
 4. Take away the rivet wrapper
 5. Insert the mandrel in the tool, by opening the jaws of the head
 6. Lock the tool jaws on the mandrel

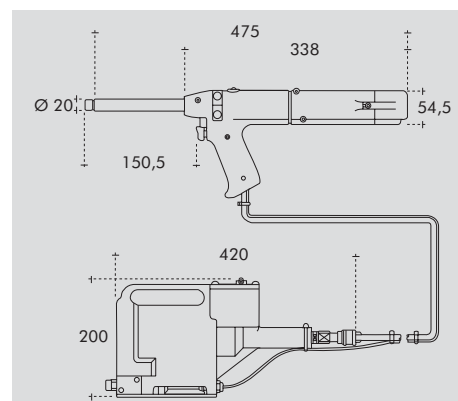
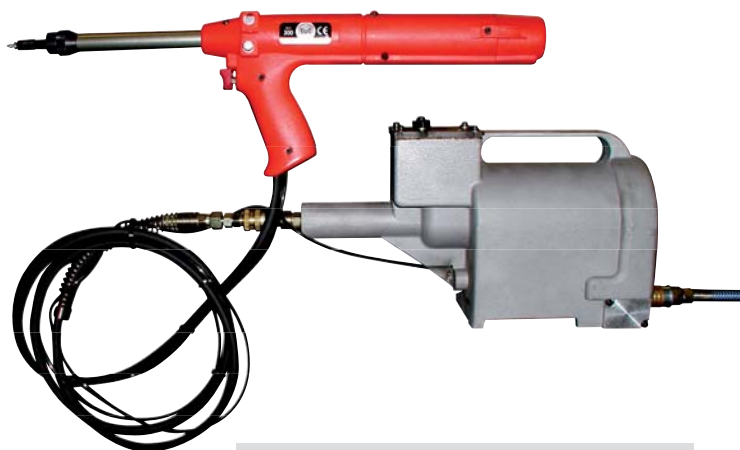

Dati tecnici e caratteristiche:

Technical data and features:

Pressione aria fornita (min/max) <i>Air supply pressure (min/max)</i>	5-7 bar
Volume aria necessaria (5.1 bar) <i>Air volume required (5.1 bar)</i>	2.6 litri litres
Corsa (min) <i>Stroke (min)</i>	30 mm
Forza di trazione (5.1 bar) <i>Pull force (5.1 bar)</i>	3.890 N
Durata ciclo (appross.) <i>Cycle time (approx.)</i>	1 secondo second
Livello di rumore (meno di) <i>Noise level (less than)</i>	70 dB (A)
Peso <i>Weight</i>	1.08 kg
Vibrazioni <i>Vibration</i>	< 2.5 m/s ²



I rivetti in caricatore sono disponibili in alluminio, acciaio zincato e acciaio inox a testa tonda e svasata nei Ø 3,2, 4,0 e 4,8
The rivets in cartridge are available in aluminium, zinc coated steel and stainless steel dome head and countersunk head Ø 3.2, 4.0 and 4.8.

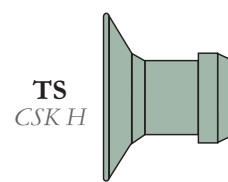
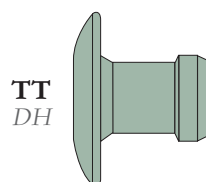

Testate per RIV 300

Heads for RIV 300

Testate standard

Standard heads

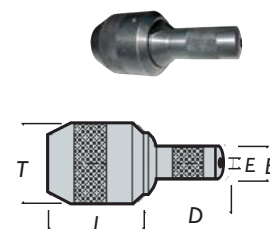
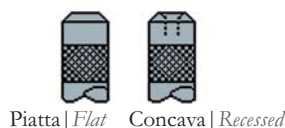

Ø rivetto <i>Rivet Ø</i>	L	T	D	B	E	Forma estremità <i>End shape</i>	Codice <i>Code</i>	
mm	mm	mm	mm	mm	mm		-	pz
3.2	33.9	28.5	10.15	29.90	5.00	Standard piatta <i>Standard flat</i>	30195	1
			10.15	30.40	7.60	Standard concava <i>Standard recessed</i>	30298	1
4.0	33.9	28.5	12.27	33.20	6.10	Standard piatta <i>Standard flat</i>	30231	1
			12.27	33.50	10.40	Standard concava <i>Standard recessed</i>	30299	1
4.8	33.9	28.5	14.23	29.90	8.30	Standard piatta <i>Standard flat</i>	30281	1
			14.23	30.40	11.90	Standard concava <i>Standard recessed</i>	30300	1

Per la testata standard abbinare il mandrino corto | *With standard head you must use short mandrel*

Testate lunghe

Long heads

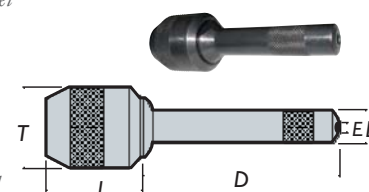
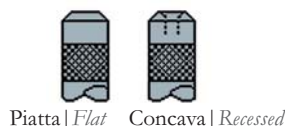

Ø rivetto <i>Rivet Ø</i>	L	T	D	B	E	Forma estremità <i>End shape</i>	Codice <i>Code</i>	
mm	mm	mm	mm	mm	mm		-	pz
3.2	33.9	28.5	58.00	9.80	5.00	Standard piatta <i>Standard flat</i>	30290	1
			58.88	9.80	7.60	Standard concava <i>Standard recessed</i>	30301	1
4.0	33.9	28.5	58.40	12.20	6.10	Standard piatta <i>Standard flat</i>	30292	1
			58.40	12.90	10.40	Standard concava <i>Standard recessed</i>	30302	1
4.8	33.9	28.5	58.40	14.20	8.30	Standard piatta <i>Standard flat</i>	30294	1
			58.40	14.20	11.90	Standard concava <i>Standard recessed</i>	30303	1

Per la testata lunga abbinare il mandrino lungo | *With long head you must use long mandrel*

Testate lunghe curve

Long curved heads

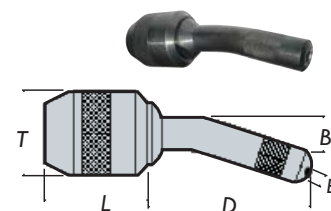
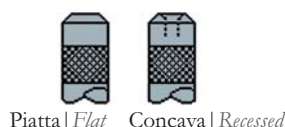

Ø rivetto <i>Rivet Ø</i>	L	T	D	B	E	F	Forma estremità <i>End shape</i>	Codice <i>Code</i>	
mm	mm	mm	mm	mm	mm	mm		-	pz
3.2	33.9	28.5	57.70	10.54	5.00	15.70	Standard piatta <i>Standard flat</i>	30295	1
			55.85	10.54	7.60	15.70	Standard concava <i>Standard recessed</i>	30304	1
4.0	33.9	28.5	60.60	12.30	6.10	17.50	Standard piatta <i>Standard flat</i>	30296	1
			60.60	12.30	10.40	17.50	Standard concava <i>Standard recessed</i>	30305	1
4.8	33.9	28.5	60.60	14.22	8.30	18.30	Standard piatta <i>Standard flat</i>	30297	1
			56.10	14.30	11.90	18.30	Standard concava <i>Standard recessed</i>	30306	1

Per la testata lunga curva abbinare il mandrino lungo e piegarlo a mano in base all'inclinazione della testata stessa.

La scelta della testata piatta o concava dipende dal tipo di rivettatura che dobbiamo ottenere (deformazione della testa del rivetto più o meno bombata), in relazione anche al tipo di materiale o spessori che si devono assemblare. Richiedere consigli al ns. ufficio tecnico.

With long curved head you must use long mandrel, and bend it manually, to follow the shape of the jaw. You have to select a flat or a recessed head according to the kind of riveting to be done (more or less rounded deformation of the rivet), and also to the type of material and thickness you have to assemble.

For any information please contact our Technical Dept.

Perchè viene utilizzata la testata standard piatta o concava?

Standard piatta: utilizzata per BR a testa tonda e svasata.

Standard concava: utilizzata solo per BR a testa tonda, aiuta ad accorciare lo spessore serrabile.

How to choose the standard flat or countersunk head.

Standard flat: to place BR with both dome or recessed head.

Standard recessed: to place BR with dome head only. It helps to shorten the grip range.

Mandrini serie BR per RIV 300

BR mandrels for RIV 300



Mandrini corti per rivetti BR

Short mandrels for BR rivets

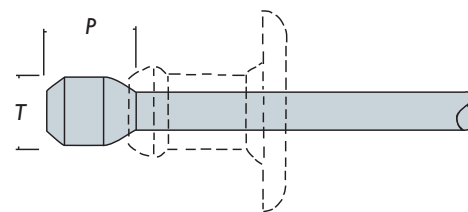

Per alluminio e acciaio zincato

For aluminium and zinc coated steel

Ø rivetto Rivet Ø	Ø foro Hole Ø	T	P	Tipo Type	Colore Colour	Codice Code	
mm	mm	mm	mm	-	-	-	pz
3.2	3.25	2.34	3.05	Standard Standard	Verde Green	30194	10
	3.40	2.46	3.20	1 maggiorazione 1st oversize	Giallo Yellow	30307	10
	3.50	2.59	3.38	2 maggiorazione 2nd oversize	Blu Blue	30308	10
4.0	4.00	2.79	3.45	Standard Standard	Verde Green	30309	10
	4.10	2.92	3.61	1 maggiorazione 1st oversize	Giallo Yellow	30310	10
	4.25	3.05	3.78	2 maggiorazione 2nd oversize	Blu Blue	30311	10
4.8	4.85	3.58	3.99	Standard Standard	Verde Green	30312	10
	5.00	3.71	4.17	1 maggiorazione 1st oversize	Giallo Yellow	30313	10
	5.10	3.84	4.32	2 maggiorazione 2nd oversize	Blu Blue	30314	10

Per inox

For stainless steel

Ø rivetto Rivet Ø	Ø foro Hole Ø	T	P	Tipo Type	Colore Colour	Codice Code	
mm	mm	mm	mm	-	-	-	pz
3.2	3.25	2.34	3.05	Standard Standard	Verde Green	35064	10
4.0	4.00	2.79	3.45	Standard Standard	Verde Green	34968	10
4.8	4.85	3.58	3.99	Standard Standard	Verde Green	35024	10

Mandrini lunghi per rivetti BR

Long mandrels for BR rivets

Per alluminio e acciaio zincato

For aluminium and zinc coated steel

Ø rivetto Rivet Ø	Ø foro Hole Ø	T	P	Tipo Type	Colore Colour	Codice Code	
mm	mm	mm	mm	-	-	-	pz
3.2	3.25	2.34	3.05	Standard Standard	Verde Green	30315	10
	3.40	2.46	3.20	1 maggiorazione 1st oversize	Giallo Yellow	30316	10
	3.50	2.59	3.38	2 maggiorazione 2nd oversize	Blu Blue	30317	10
4.0	4.00	2.79	3.45	Standard Standard	Verde Green	30318	10
	4.10	2.92	3.61	1 maggiorazione 1st oversize	Giallo Yellow	30319	10
	4.25	3.05	3.78	2 maggiorazione 2nd oversize	Blu Blue	30320	10
4.8	4.85	3.58	3.99	Standard Standard	Verde Green	30321	10
	5.00	3.71	4.17	1 maggiorazione 1st oversize	Giallo Yellow	30322	10
	5.10	3.84	4.32	2 maggiorazione 2nd oversize	Blu Blue	30323	10

Per le testate standard, utilizzare mandrini corti, per le testate lunghe, utilizzare mandrini lunghi, inoltre quando si usano le testate curve, i mandrini devono essere piegati a mano in base alla curvatura della testata, assicurando così un'alimentazione ottimale di rivetti. I mandrini devono essere selezionati in base al tipo e dimensione del rivetto e alla dimensione del foro nel quale si andrà ad applicare il rivetto. L'utilizzo del mandrino sbagliato potrebbe aumentare il rischio di rotture e l'usura della testa del mandrino. I mandrini sono soggetti ad usura, per evitare qualsiasi rischio di rotture, sostituire il mandrino dopo aver applicato circa 30.000 rivetti.

With standard beads you have to use short mandrels, with long beads you have to use long mandrels. When you use curved beads, you have to bend the mandrels manually in order to ensure a perfect loading of the rivets. Mandrels are to be chosen according to the rivet type and size, and according to the hole Ø where the rivet has to be fixed. If you use a wrong mandrel you could cause breakages and wear and tear of the mandrel head. Mandrels are subject to wear and tear. To avoid breakages, you have to change the mandrel after fastening about 30.000 rivets.



Molle per RIV 300

Springs for RIV 300



Molle per mandrini corti

Springs for short mandrels



Ø rivetto <i>Rivet Ø</i>	Codice <i>Code</i>	
mm	-	pz
3.2	30324	1
4.0	30325	1
4.8	30326	1

Le molle per mandrini corti sono da utilizzare con testate standard.
To be used with standard beads.

Molle per mandrini lunghi

Springs for long mandrels

Ø rivetto <i>Rivet Ø</i>	Codice <i>Code</i>	
mm	-	pz
3.2	30327	1
4.0	30328	1
4.8	30329	1

Le molle per mandrini lunghi sono da utilizzare con testate lunghe.
To be used with long beads.

CURSORI E MORSETTI

Cursori e morsetti per RIV 300

Cursors and clamps for RIV 300



Ricambi

Spare parts

Descrizione <i>Description</i>	Codice <i>Code</i>	
-	-	pz
Cursore universale <i>Universal cursor</i>	30331	1

Il cursore montato sul mandrino ha la funzione di far avanzare il rivetto ad ogni rivettatura.
The cursor installed on the mandrel makes the rivet move forward during the riveting.



Descrizione <i>Description</i>	Codice <i>Code</i>	
-	-	pz
Morsetti universali 2 pz <i>Universal clamps 2 pcs</i>	30330	1

I morsetti, posizionati nella parte posteriore della rivettatrice, bloccano il mandrino nella fase di rivettatura.
The clamps in the back of the tool block the mandrel during the riveting.

N.B. Accessori standard già compresi nella RIV 300
Standard fittings included in RIV 300



