



02 Push-to-Close Latch

Pull-to-open · Magnetic catch

Snap-in



Rivit srl via Marconi 20 - 40064 - Ozzano dell'Emilia (BO)
Per info 051 4171115 - luca.chiarelli@rivit.it

- Snap-in installation
- Optional side mount bracket

Material and Finish

Housing:

Pole pieces and mounting bracket:

Steel, zinc plated

Small, large: Barium ferrite

Medium: Strontium ferrite

Performance Details

Size	Average breakaway force
Small 300 series	8 N (1.8 lbf)
Medium 100 series	46 N (10 lbf)
Large 200 series	64 N (14 lbf)
Double magnet 800 series	105 N (23 lbf)

Operating temperature range:
-30°C (-20°F) to 115°C (240°F)

Flammability rating

UL94-HB

Installation Notes

For non-ferrous applications.
Screw-mounted and adhesive backed strikes are available. Order separately. See page 217.

Notes

Performance values shown are supplied as a general guide only.

Part Number

See table

Small

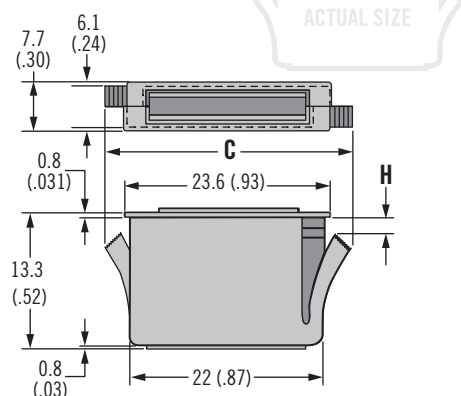

Medium

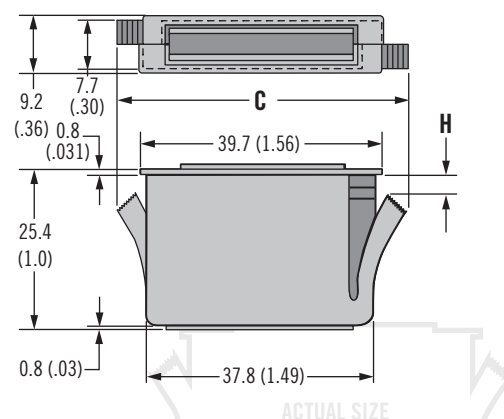

Large

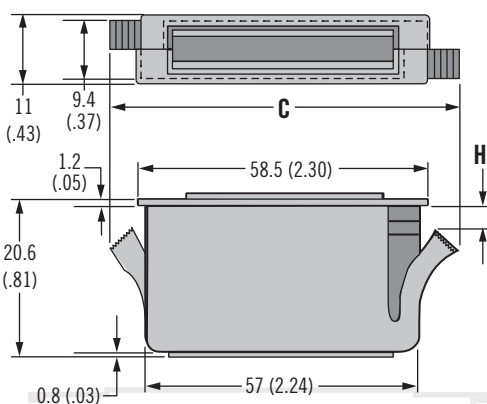

Large double magnet

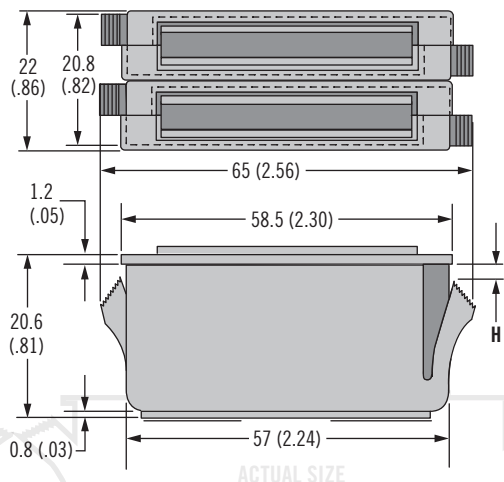

Size	C	H	Frame Thickness		Magnet Part Number	
			Minimum	Maximum	Black	White
Small	27.9 (1.10)	0.9 (.035)	0.5 (.020)	2 (.080)	02-10-301-10	02-10-301-20
	26.7 (1.05)	2.4 (.095)	2 (.080)	3.6 (.140)	02-10-302-10	02-10-302-20
Medium	47 (1.85)	1 (.040)	0.5 (.020)	2 (.080)	02-10-101-10	02-10-101-20
	46.2 (1.82)	2.5 (.100)	2 (.080)	3.6 (.140)	02-10-102-10	02-10-102-20
Large	45.5 (1.79)	4 (.160)	3.6 (.140)	5.1 (.200)	02-10-103-10	02-10-103-20
	65.3 (2.57)	0.3 (.010)	0.5 (.020)	2 (.080)	02-10-201-10	02-10-201-20
	64.5 (2.54)	1.8 (.070)	2 (.080)	3.6 (.140)	02-10-202-10	02-10-202-20
Large double magnet	63.3 (2.49)	3.3 (.130)	3.6 (.140)	5.1 (.200)	02-10-203-10	02-10-203-20
	~	0.3 (.010)	0.5 (.020)	2 (.080)	02-10-801-10	~
	~	1.8 (.070)	2 (.080)	3.6 (.140)	02-10-802-10	~
~	~	3.3 (.130)	3.6 (.140)	5.1 (.200)	02-10-803-10	~

Other options available. For complete details on variety, part numbers, installation and specification, go to



www.southco.com/02

Dimensions in millimeters (inch) unless otherwise stated

southco
CONNECT · CREATE · INNOVATE

Installation

1. Punch rectangular slot

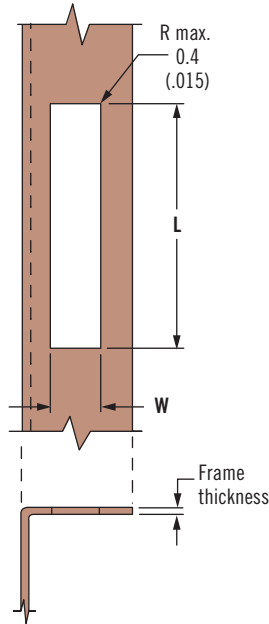

2. Snap catch into slot

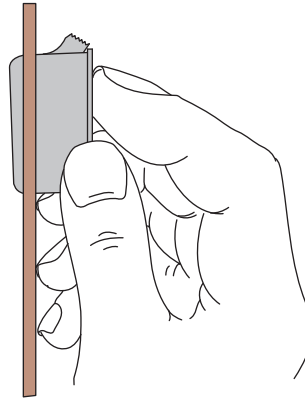

Mounting Bracket

For applications where frame is not suitable for punching (order separately)

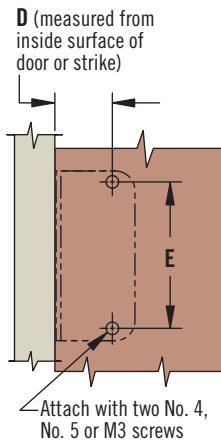
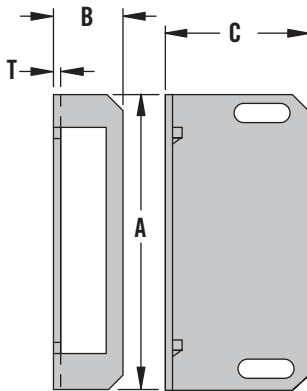

- Snap-in installation
- Optional side mount bracket

Installation Notes

Size	L ±0.1 (.005)	W ±0.1 (.005)
Small	22.2 (.875)	6.4 (.25)
Medium	38.1 (1.50)	8.1 (.32)
Large	57.1 (2.25)	9.6 (.38)
Double magnet	57.1 (2.25)	21 (.828)

Size	A	B	C	D	E ±0.1 (±.005)	T	For Use with these Magnets ONLY	Bracket Part Number
Small	41.3 (1.63)	11.1 (.44)	13.5 (.53)	7.9±2.4 (.31±.09)	35 (1.38)	1 (.042)	02-10-301-10 02-10-301-20	02-16-301-11
Medium	51 (2.00)	12.7 (.50)	24.6 (.97)	17.5±3.2 (.69±.13)	44.5 (1.75)		02-10-101-10 02-10-101-20	02-16-101-11
Large	76 (3.00)	14.3 (.56)	18.7 (.73)	12.7±3.2 (.50±.13)	70 (2.75)		02-10-201-10 02-10-201-20	02-16-201-11
Large double magnet	76 (3.00)	25.4 (1.00)	18.7 (.73)	12.7±3.2 (.50±.13)	70 (2.75)	1.6 (.062)	02-10-801-10	02-16-801-11

Part Number

See table



02 Push-to-Close Latch

Pull-to-open · Magnetic catch
Snap-in



Rivit srl via Marconi 20 - 40064 - Ozzano dell'Emilia (BO)
Per info 051 4171115 - luca.chiarelli@rivit.it

- Round hole
- Snap-in installation
- Adhesive installation
- Optional side mount bracket

Material and Finish

Housing: Polypropylene, black
Pole pieces: Steel, zinc plated
Magnet: Barium ferrite

Performance Details

Size	Average breakaway force
100 series	46 N (10 lbf)
200 series	64 N (14 lbf)
300 series	8 N (1.8 lbf)
400 series	18.5 N (4.2 lbf)
600 series	49 N (11 lbf)

Operating temperature range:
-30°C (-20°F) to 115°C (240°F)

Flammability rating: UL94-HB

Installation Notes

For non-ferrous applications.
Screw-mounted and adhesive backed strikes are available.
Order separately. See page 217.

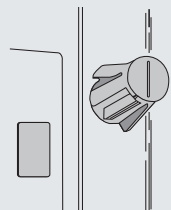

Notes

Performance values shown are supplied as a general guide only

Part Number

See table

Other options available. For complete details on variety, part numbers, installation and specification, go to



www.southco.com/02

Series 100 - Part Number 02-30-121-10

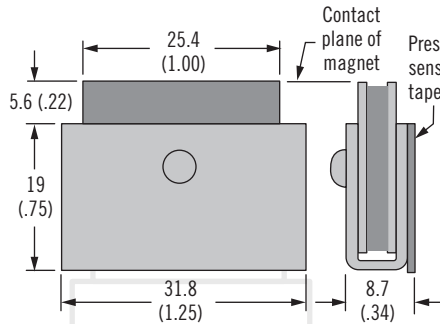

Series 200 - Part Number 02-30-221-10

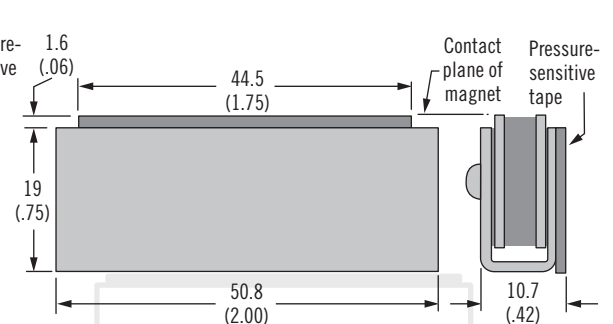

Small - 400 Series

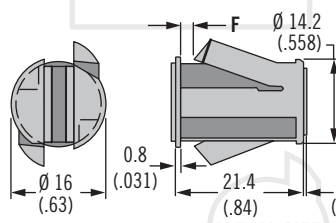

Large - 600 Series

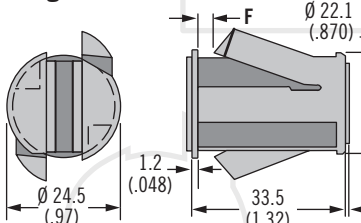

Series 300 - Part Number 02-30-321-10

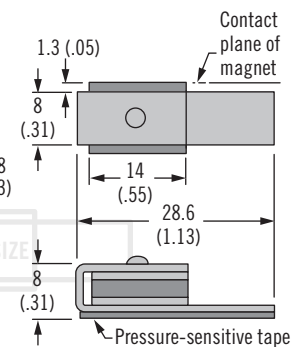

Installation

1. Drill or punch hole

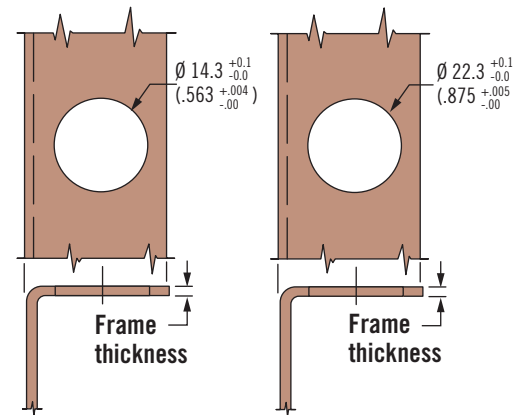

2. Snap catch into hole

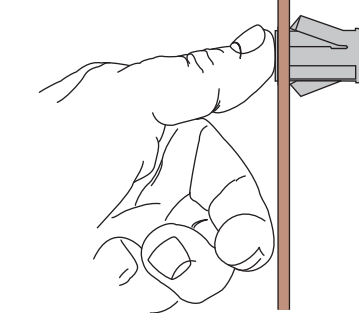

Installation

1. Remove protective paper

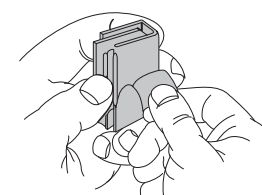

2. Place in position

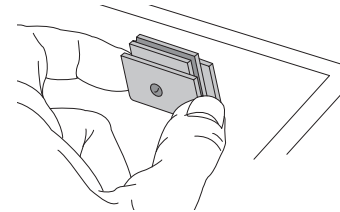

Notes: Be sure the mounting surface is clean and capable of retaining a satisfactory adhesive bond

Size	ØD	F	Frame Thickness		Magnet Part Number
			Minimum	Maximum	
Small	Ø 14.3 ^{+0.1} / _{-0.0} / (.563 ^{+0.004} / _{-0.00})	0.8 (.030)	0.5 (.020)	2 (.080)	02-20-411-10
		2.3 (.090)	2 (.080)	3.5 (.140)	02-20-412-10
		3.8 (.150)	3.5 (.140)	5 (.200)	02-20-413-10
Large	Ø 22.3 ^{+0.1} / _{-0.0} / (.875 ^{+0.005} / _{-0.00})	0.5 (.020)	0.5 (.020)	2 (.080)	02-20-611-10
		2 (.080)	2 (.080)	3.5 (.140)	02-20-612-10
		3.5 (.140)	3.5 (.140)	5 (.200)	02-20-613-10

Dimensions in millimeters (inch) unless otherwise stated



02 Push-to-Close Latch

Steel strikes

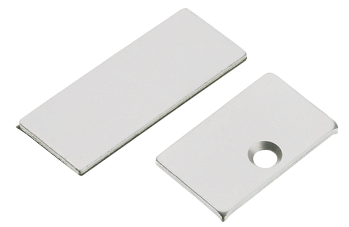

Self-adhesive

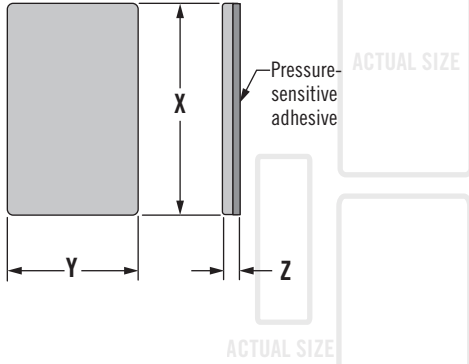

For Use with Series Catch	Strike Part Number	X	Y	Z
300	02-14-301-14	24	8	2
400		(.94)	(.31)	(.08)
100	02-14-101-14	32	19	2.4
600		(1.25)	(.75)	(.094)
200	02-14-201-14	51	19	2.4
800		(2.00)	(.75)	(.094)

- Ferrous keepers for magnet catch
- Self-adhesive or screw mount

Material and Finish

Steel, zinc plated

Adhesive:

Neoprene foam with acrylic

Installation Notes

Be sure the mounting surface is clean and capable of retaining a satisfactory adhesive bond.

Self-adhesive mounted strikes are designed to function under intermittent break-away loads. Use screw-mounted strikes for continuous load applications.

Part Number

See table

Installation

1. Position strike on installed catch

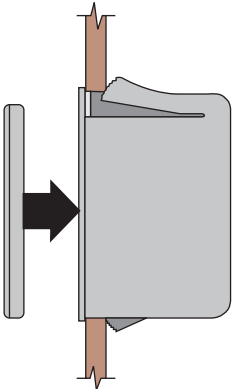

2. Remove protective paper. Close door or panel onto strike

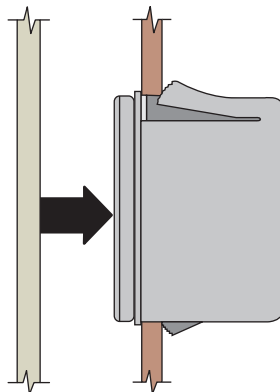

Screw-Mounted

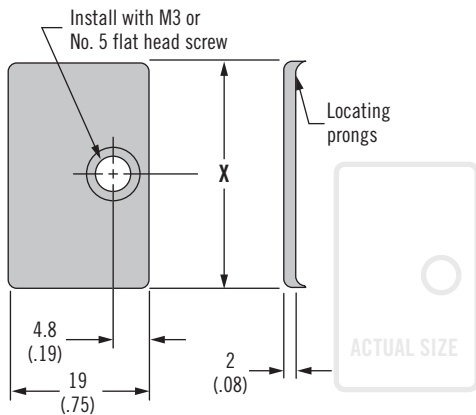

For Use With Series Catch	Strike Part Number	X
100	02-14-102-11	32 (1.25)
600		
200	02-14-202-11	51 (2.00)
800		